The World Wide Web as a Universal Interface to Government Services

Project Report 96-2



**Center for Technology in Government
University at Albany / SUNY**

This report is available on the CTG Web site as both a downloadable and a hypertext document.

Since this report contains hundreds of links to sites on the WWW, we recommend that readers use the hypertext version which also contains a search engine and other navigation aides.

**The hypertext document is located at
<http://www.ctg.albany.edu/resources/htmlrpt/ittfnlrp.html>**

**The downloadable document is located at
<http://www.ctg.albany.edu/resources/pdfrwp/ittfnlrp.pdf>**

Note: It is the nature of the Web that links move or become inactive over time.

The URLs provided in this report were all active and relevant in December 1996.

The World Wide Web as a Universal Interface to Government Services

Project Report 96-2

Editors

Ann DiCaterino
Theresa A. Pardo

Contributors

Center for Technology in Government
SUNY System Administration
Deloitte and Touche Consulting Group/DRT Systems
NYSERNet
Silicon Graphics

December 1996

Center for Technology in Government
University at Albany
Albany, NY 12222
phone: (518) 442-3892
fax: (518) 442-3886
e-mail: info@ctg.albany.edu
<http://www.ctg.albany.edu>

Acknowledgments

The Universal Interface Project of the Internet Technologies Testbed involved more participants in prototype development than any previous CTG project. Staff from several organizations conducted technology investigations and developed prototypes in four service areas: information dissemination, business applications, group collaboration, and education. We acknowledge with thanks their dedication to the project and their unique and valuable contributions to a better understanding of how the Web can help improve services to the public.

Information Dissemination

- Silicon Graphics** Nelson Frolund, Manufacturing Industries Engineer
Andrew Schein, Systems Engineer
- Center for Technology in Government** Ann DiCaterino, Project Support Manager
Donna Berlin, Internet Coordinator
Kai Larsen, Graduate Assistant
Mei-Huei Tang, Graduate Assistant
Wen-Li Wang, Graduate Assistant
Derek Werthmuller, Systems Administrator

Business Applications

- SUNY System Administration** Edward J. Urschel, Director of Systems Development For
Finance and Management
Bruce D. Briggs, Manager of Technical Services
Thomas F. Cusack, Project Manager
Michael J. Plowinske, Manager of Systems Programming
- Deloitte & Touche Consulting
Group/DRT Systems** Ronald R. Schrimp Sr., Project Manager
Cecil Elmore, Public Relations, Project Advisor
Ramesh Karan, Internet Developer
Jeff Older, Technical Architect
Stefan Estus, Internet Developer
Ramesh Karan, Internet Developer
- NYSERNet, Inc.** James P. Brennan, Assistant Director of Government Services
Denis J. Martin, Senior Director of Software Engineering
- Center for Technology in Government** Ann DiCaterino, Project Support Manager

Group Collaboration

- University at Albany** John Rohrbaugh, Professor, Department of Public
Administration and Policy
Eliot Rich, Student, Information Science Doctoral Program
- SUNY System Administration** Joseph W. Sasiadek, Coordinator of System Integration
- Center for Technology in Government** Ann DiCaterino, Project Support Manager
Mei-Huei Tang, Graduate Assistant
Wen-Li Wang, Graduate Assistant

Education

- SUNY Plattsburgh** William D. Graziadei, Professor, Department of
Biological Sciences
- SUNY System Administration** Joseph W. Sasiadek, Coordinator of System Integration
- Center for Technology in Government** Theresa Pardo, Project Coordinator

Table of Contents

Executive Summary	i
Chapter 1. Project Overview	1
Introduction	1
Center for Technology in Government Project	2
Chapter 2. Information Dissemination	6
Overview	6
Agents	10
Client-Side Processing	15
Concept Searching	25
Cookies.....	31
Streaming Technology	37
Virtual Reality Modeling Language	42
Chapter 3. Business Applications	47
Overview	47
Case Study of America’s Job Bank	53
Case Study of the SUNY System Administration Purchasing Card System	66
Chapter 4. Group Collaboration	89
Overview	89
Synchronous Groupware	91
Web-Based Calendar	105
Chapter 5. Education and Training Services on the Web	110
Overview	110
Current Uses of the WWW for Education and Training	112
Drawbacks and Benefits	119
References.....	120
Chapter 6. Appendices	123
A. Project Timeline	124
B. Project Participants	125
C. Related Products	127
D. Evaluation Template.....	128

Executive summary

The World Wide Web has become an increasingly important way for people and organizations to communicate. The Web offers great value to both information seekers and information providers. It promises to provide 24-hour access to information and services, to enhance learning and reduce training costs, and to allow information to be shared and integrated in new ways. This project investigated and demonstrated the potential of the Web to become a universal interface between citizens and government. The investigation included prototype development and technical evaluations of a wide variety of Web-based tools for information sharing, business applications, group collaboration, and education.

Through these investigations, the project tried to answer two questions:

- ◆ Can New York State government use the Web as a universal interface for delivery of all or most services to citizens?
- ◆ Can New York State government use the Web as a universal interface for conducting business within and among agencies?

The results indicate that the answer to both questions is a qualified “yes.” “Yes,” because tools available today can customize information search and presentation, extend the classroom into the living room, bring an office to a worker located in any remote location, extend the life of expensive legacy systems, and enhance our ability to collaborate across time and space. “Qualified,” because not every person or organization has the know-how, infrastructure, or specific tools to take equal advantage of all these capabilities. Our results are reported with these factors in mind.

The project team included government, academic, and corporate partners who together conducted a wide range of reviews and experiments within four service areas: information dissemination, business applications, group collaboration, and education and training. A number of concepts and capabilities were investigated within each area through evaluation of existing applications, development of prototypes, and a search for best practices. In each case, the technical feasibility of the capabilities was demonstrated using commercially available tools. Although limitations were encountered in nearly every instance, none was so severe that the capability could not be effectively implemented.

The team reported activities and results in two ways: by completing a standard template or by writing a case study. The template consists of a series of technical and reference questions that were answered for each application investigated in the information dissemination and group collaboration service areas. Case studies report the results and implications of the capabilities investigated in the business applications and education and training service areas.

- ◆ Information dissemination capabilities investigated included concept searching, Web agents, client-side processing, cookies, streaming, and virtual reality. These tools make it possible for information search and presentation to be personalized for a specific user. They also take advantage of the intelligence available on the desktop to gather and integrate information from many locations, in different formats and media.
- ◆ Business applications covered two complex applications: the transition of a major nationwide database, America's Job Bank, from a mainframe to a Web-based application; and the development of a prototype Web front-end linked to an existing database application at the State University of New York. Both case studies discuss the strategies and options that organizations need to consider when embarking on web-legacy projects.
- ◆ Group collaboration reviews were represented by a look at such capabilities as white-boarding, net-based meetings, and calendars. These tools allow greater participation in decision making by removing time and location as prerequisites for participation. Group collaboration tools also allow organizations to extend their information resources to their employees regardless of location or time of day.
- ◆ Educational services reviewed included both Web-based academic programs such as the State University of New York's Learning Network and professional training applications developed at Lawrence Livermore Laboratories and the US Department of Energy. These cases illustrate how the Web can be used to implement learner-centered models of education that offer more flexibility, greater opportunity for collaboration, and better access to research and reference services.

Chapter 1. Project Overview

Introduction

The World Wide Web has become an increasingly important way for people and organizations to communicate. It is being used to disseminate information and to transact business. It promises to provide 24-hour access to government information and services. As a universal interface to services the Web offers many potential benefits to both users and providers of information services. It presents a unified and user-friendly gateway to a myriad of resources; it can reduce the

learning curve and training costs; help government reach an expanded audience; give citizens anytime, anywhere convenient access to government information and services; allow government to integrate information and services which originate at different agencies and on different platforms. The objective of this project has been to examine and demonstrate the technical capabilities of the World Wide Web as a universal interface for the delivery of New York State and local government services to citizens.



The project was launched with an October 1995 workshop called "New York on the Internet." At that workshop, more than 170 people, representing state and local government and the private sector, helped craft an agenda for CTG's Internet Testbeds. Participants focused on the management,

policy, and technology dimensions of the Internet. They identified benefits and hurdles to government's use of the Internet, and defined some of the deliverables of the Testbeds. These desired deliverables exemplified how important electronic networks have become for communicating in today's world: to disseminate information, to transact business, to link remote offices to central databases, to link agencies with their suppliers and contractors, and to exchange information between agencies and levels of government. Two Internet Testbeds were initiated to address the issues and learning objectives raised by these workshops: an Internet Services Testbed which emphasized the design and delivery of information-based services, and the Internet Technologies Testbed which explored key technical issues that underlie many kinds of networked services.

The primary objective of the Internet Technologies project was the examination and demonstration of the World Wide Web as a universal interface for the delivery of New York State services to citizens. Specifically the project posed two questions:

- ◆ Can New York State government use the Web as a universal interface for delivery of all or most services to NY State citizens?
- ◆ Can New York State government use the Web as a universal interface for conducting business within and among agencies?

In this “proof of concept” effort the project team investigated existing applications; developed prototypes; conducted hands-on experiments, instructional activities, and demonstrations; and documented their implementation experiences in the following four service areas:

- ◆ Information Dissemination
- ◆ Business Applications
- ◆ Group Collaboration
- ◆ Education

Center for Technology in Government Project

In the late fall of 1995 a call for proposals was distributed for the Internet Technologies Testbed. Six proposals were received and two proposals were selected for investigation and prototyping.

- ◆ Demonstrate the use of the WWW as a common interface for a variety of services/activities
- ◆ Implement prototype application(s) which interface production systems with Web clients

The project team included the following government and academic partners:

- ◆ SUNY System Administration
- ◆ Division of Housing and Community Renewal
- ◆ Empire State College, Center for Learning and Technology
- ◆ NYS Forum for Information Resource Management
- ◆ Office of Real Property Services
- ◆ SUNY Plattsburgh
- ◆ University at Albany
- ◆ NYSERNet
- ◆ CTG professional staff and graduate students

The project team also included six corporate partners. Deloitte & Touche/DRT Systems and Bluestone, Inc. were instrumental in the development of the SUNY Web to Legacy prototype. EMI Communications Corporation and NYNEX provided the necessary technology and assistance to support the public presentation of the project results. This event included 16 Internet connections for live demonstrations of the prototypes as well as two Internet connections which supported the six Web-based presentations. Silicon Graphics supported the project by presenting its VRML products as part of the Information Dissemination service area. Microsoft Corporation also provided support for the Group Collaboration service area by demonstration of its NetMeeting product.

Project objectives

The Center worked with two groups within SUNY System Administration, the Office of Educational Technology and System Administration, to investigate whether New York State government can or should use the Web as a universal interface for the delivery of all or most services to NY State citizens and for conducting business within and among agencies.

The methodology used for this investigation was:

1. Identify all of the types of services currently offered/needed by SUNY System Administration.
2. Determine whether each service can be effectively delivered over the Web in 1996. The intent was simply to prove that the service could be effectively delivered using the Web, by building a prototype application or by evaluating similar existing systems.
3. Identify the functional needs of SUNY System Administration and determine what is and is not technically “doable” using a Web interface.
4. Share findings through a public demonstration and report.

Project workplan

Planning for the Universal Interface project activities began in March 1996. Early planning sessions resulted in the identification service areas that could be investigated as part of the project work.

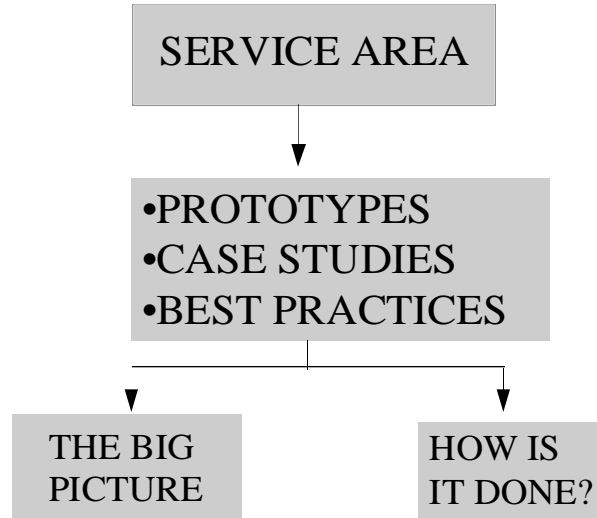

A number of concepts and capabilities were identified in each service area along with potential products or applications that would be evaluated or prototyped. Each of these concepts and capabilities was assigned to either the CTG technical staff or the SUNY Central Administration staff for research, implementation, demonstration, and reporting.

Table 1 lists the four service areas, and the concepts and capabilities investigated in each.

Each of the next four chapters of this report covers one of the four service areas: Information Dissemination, Group Collaboration, Education, and Business Applications.

Table 1. Four Service Areas and the Concepts/Capabilities Investigated	
Information Dissemination	<ul style="list-style-type: none"> Concept searching Personalized pages Audio Streaming Video Streaming Multi-Media VRML
Business Applications	<ul style="list-style-type: none"> Interactive forms using client-side editing Real-time interactions with production systems Interface to legacy systems: putting mainframe transactions on the Web "as is" Interface to legacy systems: mirroring legacy database on a Web accessible database Interface to legacy systems: live connection to database using middle-ware Integration of multiple back-end systems/platforms with single web front-end
Group Collaboration	<ul style="list-style-type: none"> Asynch conferencing Document/file sharing White boarding Data Sharing Calendar/scheduling
Educational Services	<ul style="list-style-type: none"> Distance learning Web-based training Web-based education

Each chapter begins with an overview of the service area and then presents results. The concepts and capabilities were examined from primarily a technical/functional perspective (i.e. what is technically feasible, effective, efficient). Two methodologies were used to report results: a question template and case studies. The question template provides consistency of review in evaluating the various products and applications. The template consists of a series of questions that were answered for each potential application (see Appendix D). This methodology was used to report the results in the Information Dissemination and Group Collaboration chapters. Case studies were used to examine where we are in the transition to the Web as a universal interface. The case study method was used to report results in the Education and Business Applications chapters.

Chapter 2.

Information Dissemination

Overview

The World Wide Web originated as a means of sharing information among a dispersed group of people and this ready access to data and knowledge is still the predominant reason most people sign on to the Web today. Governments at all levels are using the Web to improve citizen access to their data. Among the potential benefits are: helping governments reach an expanded audience; giving citizens anytime, anywhere access to government information; providing a single point of entry to data from diverse sources; providing a customer view of information rather than an agency view; presenting a more unified and user-friendly interface for accessing government data; and making use of graphics, audio, and video to add impact, ease-of-use, and improved clarity. In addition, many of these same benefits can be realized by using the Web to share information within and among agencies. The Web can serve as a unifying factor, improving the vital communications needed to integrate a diverse and distributed work force.

Although information dissemination is the most obvious and familiar of the service areas examined, there are many new trends on the horizon which are beginning to change the nature of this service. These changes add significant value to traditional mechanisms for exchanging information. They offer compelling reasons for using the Web from the standpoints of both the information deliverer and the information seeker. Significant among these trends are:

- ◆ **Personalized presentation of data.** The World Wide Web allows organizations to create a single presentation which can reach many people. Interestingly, though, this strong benefit sometimes turns into a negative when the communication becomes impersonal and the Web pages overflow with “too much” information. Small steps are being made in the direction of more personalized delivery. Through the use of HTTP cookies, customers are being asked for their information preferences so that personalized news pages can be dynamically created by a server side program and delivered to the client on demand. ‘Agents’ are another mechanism for achieving similar results. These programs sit on the client’s machine and perform customized searches over the Internet for requested information.

- ◆ **Client-side processing.** The personal workstation revolutionized the computer industry by bringing the power of the computer processor to the user's desktop. Networked computing, and the Internet in particular, initiated another revolution by allowing users the opportunity to access information from around the globe. Client-side processing combines the best of these two models. It allows users to pull information from anywhere on the World Wide Web and then lets them manipulate that information on their own desktops using their Web browser. Java, JavaScript, and plug-ins are popular mechanisms for achieving client-side processing.
- ◆ **Integration of multiple forms of communication.** Integration (the ability to represent multiple types of information such as data, voice, and video by a common digital format and deregulation of the communications industry (as by the Telecommunications Act of 1996) will dramatically change the nature of information delivery. The lines of distinction among broadcasting, telephony, print and other media. will soon be blurred as these various formats are delivered over the same device. The World Wide Web is proving to be one of the forerunners in this arena. For example, audio conferencing is already providing telephone service over the Internet. In another example, streaming technology allows large chunks of information (such as a one hour speech) to be heard or seen almost immediately just as in a television broadcast; but instead of being forced to watch or tape that broadcast when it is being aired, the customer can choose what and when to view by the click of a button. As this new era continues, consumers will undoubtedly enjoy much greater control and access to information, entertainment, news, and communications with others.
- ◆ **Concept searching.** Text searching and database searching are traditional tools for discovering information. Unfortunately, these mechanisms fall short if the exact word or phrase contained in the needed document or record is unknown. Concept searching helps users to search for an idea instead of an exact word. For example, a search on 'the meaning of life' may return documents on Aristotle which do not contain any of the words in the search phrase. Concept searching is a particularly important tool for the Internet since information is coming from such diverse sources and can be expected to contain a rich variety of words.
- ◆ **Increased use of multimedia.** Audio, video, and virtual reality are currently being used by a limited number of Web sites to improve the effectiveness of their presentations. Widespread use of these

technologies will have to await improvements in bandwidth since the amount of data needed to be transmitted over the network is far greater with multimedia applications than with simple text or graphics.

Multimedia can have a tremendous impact on the effectiveness of information delivery. Instructions for assembling a complex product, for example, are more easily grasped when viewed in three dimensional mode where the product can be rotated and even seen from the inside out. As another example, a government official's address to the public has more meaning and impact when the inflections and emotions can be heard through audio, enhancing what can be gained from a written text of the same speech. As data transmission speeds continue to rise while prices for bandwidth drop, multimedia will play an ever increasing role in effective delivery of information.

Service Delivery Considerations

While the emergence of these new technologies provides exciting opportunities for improved information delivery, their use often comes at a cost. This cost may take the form of an increased demand on the service deliverer, requiring specialized skills, increased time to implement, or the cost of additional hardware and software. Perhaps even more significantly, the cost may also take the form of a reduced audience for the product. Increased bandwidth requirements or the need to use a particular Web browser or the need to download a specialized browser plug-in program may stand in the way of some of the intended audience receiving the message. With this in mind, it is important for service deliverers to look carefully at the intended audience and gauge the perceived benefits of improved service delivery against the possibility of reducing audience size when choosing a more technologically advanced method of delivery. In some cases, it may be desirable to deliver the information in more than one format - a more universal format available to all as well as a format which takes advantage of the latest technology for a more effective presentation.

It is also important to note that it is generally a matter of time (and this time may be measured in "months" in this fast-paced environment) before the wider audience has access to the more advanced resource requirements. For example, the newest Web browsers will automatically incorporate many of the plug-ins which previously

needed to be downloaded and installed, thus making their functionality more convenient for the inexperienced user. With this in mind, an organization may be more comfortable in its decision to employ higher-end solutions to meet information dissemination needs, particularly if it offers some low-tech options as well.

Practical Results

Each section below describes the application of a particular technology. The questions and answers were designed to provide practical information for those considering similar implementations.

WWW Agent

What is it?

WWW agent technology automates some time consuming tasks on the World Wide Web. The volume of material available on the Web is starting to get too big for any one person to keep up to date on specific topics. WWW agents provide automated tools that make this task easier, and enable the user to stay updated on news and changes on the Web.

WWW agents are different from Intelligent Autonomous Software Agents, which contain artificial intelligence and act by themselves. WWW agents are much less sophisticated — but are available now!

How does it work?

A WWW agent is a software program that works in the background or at times when the user is not at the computer. It checks specified Web pages (URLs) along with any pages linked to from the original URLs. It will download pages which have been changed since the previous check occurred or which meet certain filtering criteria. When the user wants to access a specific Web page, the agent creates the page from the locally stored file. In this way, the user can access Internet content without being logged onto the Internet. The user is also assured that pages being downloaded meet specified criteria.

Tasks handled include automatically downloading product updates and bug fixes, filtering and downloading web sites, issuing alerts when new products are available or when web sites have been updated, and downloading and displaying of news on specific topics of interest.

Benefits and Drawbacks

Benefits

- ◆ Some information-seeking tasks can be automated.
- ◆ Demonstrates second-generation Web agent technology.
- ◆ Gives access to Web pages when not connected to the Internet.
- ◆ Provides an archive of an old Web site, even after the WWW pages have changed.
- ◆ Some of the agents provide an interface to many other search engines.

Drawbacks

- ◆ The interface could be more intuitive.
- ◆ Threatens to swamp the Internet with unnecessary downloads. It is easy to download several megabytes when all the user really needs is one page.
- ◆ Does not allow off-line browsing of most image maps or use of other technologies that require communication with the Web server.

URLs where demonstrated

Not Applicable. It is a client side tool which is not possible to demonstrate on the server side.

Implementation Details

Describe the application where this concept / capability was used.

For this test, many functions were tested simultaneously. All options were set in the agent at the same time, but are listed in the order that the agent executed them:

1. The agent was set up to do a search on “electronic commerce” using three Internet search engines.
2. After retrieving the results from (1), the agent was asked to go to the Web pages returned by the search engines and look for links from these pages to other pages. A total of two levels of pages was retrieved (the pages that the search engines pointed out as relevant, and all pages linked to from these pages).
3. The resulting group of pages were saved on the computer’s hard disk and a more refined search was conducted on these pages.
4. The agent then created a new page (called a brief) with links to the different types of information. The brief included unfiltered top-pages, a site map, and the result of the refined search.

At this point, the user can browse all the information retrieved without being connected to the Internet.

The reason why this test was chosen was because of the shortcomings of Internet search engines. Often, they do not download all Internet pages and seldom update the pages they do download. This way of searching provides more up-to-date and extensive search capabilities.

What tool(s) were used and where did we find these tool(s)?

NetAttaché Pro, created by Tympani Development, Inc. The NetAttaché Pro system contains a client and a server. They can be downloaded in the same package from Tympani (<http://www.tympani.com>).

What other tools are out there which do the same thing?

- ◆ Teleport Pro (<http://www.tenmax.com/>) Teleport Pro is developed by Tennyson Maxwell Information Systems.

- ◆ InContext WebAnalyzer (<http://www.incontext.ca/>) InContext WebAnalyzer is developed by InContext Systems.
- ◆ WebCompass (<http://www.qdeck.com>) WebCompass is developed by Quarterdeck Corporation.
- ◆ WebFerret (<http://www.vironix.com>) WebFerret is developed by Vironix Software Laboratories.

Why did we choose this tool?

At the time of writing, NetAttaché Pro received excellent reviews, some of which can be found on their review page (<http://www.tympani.com/Reviews.html>). Some of these reviews found NetAttaché Pro to be the best WWW agent available.

What restrictions are placed on the client?

NetAttaché Pro requires a Microsoft Windows operating system.

What was the level of effort to implement? Summarize the implementation steps.

It was very easy to implement. Software was downloaded and a few questions were answered in the standard MS Windows installation procedure.

What did we learn about the concept / capability through implementation?

The concept is far from being a panacea. It is still limited in many ways, but can be expected to grow rapidly over the next few years. It is well worth monitoring.

How might the concept / capability be employed for other applications?

It can be used to enhance traditional searching over the Internet which uses search engines alone. It also makes it possible to monitor Web sites, which might be useful for the Webmaster. It is also useful for those who do not have unlimited Internet access and who wish to browse Web pages offline.

How does it contrast to other methods for doing the same thing?

Other methods for doing the same thing are to use traditional online search engines or to register with an e-mail service that notifies you when Web pages have been updated.

The agent provides more timely information than search engines, since most of these cannot update pages in their database as often as an agent can update pages on a local machine. The agent provides less information than a search engine, and therefore cannot replace it; but it is a good addition. Registering with an e-mail service can flood the e-mail inbox and offers less options for the user.

Benefits and drawbacks of the specific tool(s) used.

Benefits:

- ◆ Includes a filter to find changes to Web pages.
- ◆ Provides a front-end for Web search engines / directories.
- ◆ Provides compact data storage.
- ◆ Provides an archive to manage Web data.
- ◆ Features multi-socket support for faster data retrieval.

Drawbacks:

- ◆ Interface could be more intuitive.
- ◆ Only works with Microsoft Windows.

References for more information

- ◆ NetAttaché Pro:
<http://www.tympani.com/products/NetAttache.html>
<http://www.tympani.com/products/NAFAQ.html>
- ◆ Teleport Pro: <http://www.tenmax.com/pro.html>
- ◆ InContext WebAnalyzer:
<http://www.incontext.ca/products/analyze.html>
- ◆ WebCompass:
<http://arachnid.qdeck.com/qdeck/products/wc20/>
- ◆ WebFerret: <http://www.vironix.com/netferret/>

Client-Side Processing

What is it?

Client-side processing is the ability to respond to user-initiated events (for example, a form input) without messages being sent back and forth between the client machine (used by the customer) and the server machine (used by the organization). It can be thought of as a program which can be run on the client. It results in more immediate feedback to the user. Even more importantly, it provides an opportunity for Web applications to be designed with greater interactivity since connectivity speed and response times are not such large issues. It has been utilized to display animated graphics, to add functionality, to verify data, to play audio files, etc.

How does it work?

There are three popular tools for client-side processing: JavaScript, Java, and plug-ins. Other tools are being made available, such as Microsoft's Active-X.

JavaScript is programming code which is embedded into the Web page's HTML code. When a specific action is taken by the client, the programming code is initiated by the Web browser.

A Java applet is a Java program which has been compiled and can be included in an HTML page, much like an image can be included. When you use a Java-compatible browser to view a page that contains a Java applet, the applet's code is transferred to your system and executed by the browser.

Plug-ins are programs which need to be downloaded and which seamlessly interact with the browser. Similar to Java, plug-ins have program code which is accessed from the HTML page. But the code is run by the plug-in software instead of by the browser. Many plug-ins now come bundled with the newer browsers (such as Netscape 3.0), so that you do not need to download each one separately.

Benefits and Drawbacks

Benefits

- ◆ Client-side processing reduces server load and provides faster feedback to the page visitor.
- ◆ It allows users to obtain resources from the Internet and yet take advantage of their own computer's power to process data in real-time.

Drawbacks

- ◆ A Web browser which supports JavaScript, Java, or plug-ins, is required. JavaScript works on Netscape 2.x and higher or Internet Explorer 3.0. Java works with the same browser versions, but cannot work on any browser for Windows 3.1 since it requires a 32 bit operating system. Plug-ins may require the user to download and install their software.
- ◆ JavaScript and Java work slightly differently for various Web browsers. With each new version of the Web browser, additional features are added and errors are corrected.

URLs where demonstrated

- ◆ Cost Estimation Spreadsheet
(<http://www.ctg.albany.edu/projects/inettb/univ/SpreadSheets.html>), described below.
- ◆ Java Spreadsheet
(<http://java.sun.com/applets/applets/SpreadSheet/example1.html>)
- ◆ Formula One/NET samples
(<http://www.visualcomp.com/f1net/live.htm>)

Implementation Details

Describe the application where this concept / capability was used.

(<http://www.ctg.albany.edu/projects/inettb/univ/SpreadSheets.html>)

A Cost Estimation Spreadsheet was developed which helps users to identify the costs and benefits associated with developing a Web site. Totals are calculated instantly after each input to the spreadsheet.

What tool(s) were used and where did we find these tool(s)?

- ◆ JavaScript
(<http://www.gamelan.com/frame/Gamelan.javascript.html>)
- ◆ JavaScript Authoring Guide
(<http://www.gamelan.com/pages/Gamelan.related.javascript.html>)
- ◆ Formula One/NET
(<http://www.visualcomp.com/f1net/download.htm>)

What other tools are out there which do the same thing?

- ◆ Java (<http://java.sun.com/aboutJava/index.html>)
- ◆ NCompass Script Active (<http://www.ncompasslabs.com/products/scriptActive.html>)

Implementation using JavaScript

Why did we choose this tool?

- ◆ JavaScript is a new technology which represents the next generation of software designed specifically for the Internet.
- ◆ JavaScript is currently supported by the Netscape browser (versions 2.0 or higher), so that anyone using this browser can take advantage of JavaScript coding - regardless of what machine or operating system is being used. JavaScript will work with Windows 3.x while Java cannot.
- ◆ A large number of other companies have agreed to adopt JavaScript, so we can expect other browsers to support this language before too long.

What restrictions are placed on the client?

The client needs a Web browser which supports JavaScript such as Netscape 2.x or higher. Since the scripts are run on the client side, the performance is dependent on the client's CPU speed and how many processes are running concurrently.

What was the level of effort to implement? Summarize the implementation steps.

It is easier to write JavaScript applications with some programming experience and with knowledge of object oriented concepts. Furthermore, it is important to understand the JavaScript language itself: the properties, methods and functions of each JavaScript object and how event handlers work (such as onChange, onFocus and onSelect, etc). With no JavaScript experience and a sample script from the Web, it took nine days to learn the language and complete the application. Since there are different results based on the different browser versions, it took an additional three days to understand these differences and modify the scripts to work most effectively with both Netscape 2.x and Netscape 3.x. For an experienced JavaScript programmer, it may take three to five days to get this program done.

Implementation steps:

1. Create the Web input form using HTML code.

2. Add the JavaScript event handlers into the HTML code. These automatically activate the sum function, check function, clear form function, etc.
3. Code each function using JavaScript.
4. Test and modify the code to work on different browser versions.

What did we learn about the concept / capability through implementation?

We found that JavaScript works slightly differently on different browser versions. For example, in Netscape 2.x, when we 'set focus' to a specific field on the form, the cursor disappears. This problem is solved in Netscape 3.x. Furthermore, some versions of Netscape can handle nested tables very well using only one global form `<form> ... </form>`, but the others only support one table per form and must specify a name for each form. Because of the differences on different browser versions, it is necessary to test multiple browsers before going public.

How might the concept / capability be employed for other applications?

In a client application for Navigator, JavaScript statements embedded in an HTML page can recognize and respond to user events such as mouse clicks, form input, and page navigation. You can therefore write a JavaScript function to verify that users enter valid information into a form, manipulate the information entered, or perform an action (such as play an audio file, execute an applet, or communicate with a plug-in) in response to the user opening or exiting a page. It is also being used increasingly to execute client-side image maps (<http://curry.edschool.virginia.edu/go/WebTools/Imagemap/home.html>).

How does it contrast to other methods for doing the same thing?

Plug-ins are application specific (as opposed to general programming languages such as Java and JavaScript which allow you to create your own application). Plug-in files are generally easier to create since the software creator will supply you with user-friendly tools for developing your application. Plug-in files are usable by the client only when the corresponding plug-in software is installed.

Java(tm) is a full-featured object-oriented programming language

developed by Sun Microsystems. Intended for experienced programmers, Java can be used to create downloadable program fragments (applets) that augment the functionality of a Java-capable browser. It can also be used to create standalone applications which are platform-independent.

JavaScript statements are embedded in an HTML page and are interpreted at run time. JavaScript(tm) is a simpler language developed by Netscape (suitable for casual programmers or in some cases, non-programmers) that is used to create dynamic behavior in elements of the Web page.

The following table compares and contrasts JavaScript and Java.

JavaScript	Java
Interpreted (not compiled) by client.	Compiled on server before execution on client.
Object-based. Code uses built-in, extensible objects, but no classes or inheritance.	Object-oriented. Applets consist of object classes with inheritance.
Code integrated with, and embedded in HTML.	Applets distinct from HTML (accessed from HTML pages).
Variable data types not declared (loose typing).	Variable data types must be declared (strong typing).
Dynamic binding. Object references checked at run-time.	Static binding. Object references must exist at compile-time.
Cannot automatically write to hard disk.	Cannot automatically write to hard disk.

Benefits and drawbacks of the specific tool(s) used.

Benefits:

- ◆ JavaScript allows program scripts to be embedded in the Web document. These scripts can allow greater interaction to take place right on the client machine, without a need to send messages back and forth between the client and server.
- ◆ JavaScript is a fairly simple programming language to use.
- ◆ JavaScript is platform-independent.
- ◆ JavaScript extends the features of graphics in HTML pages by

making image selection and appearance dynamic. Using JavaScript, it is possible to conditionally choose graphic files for use on a page, resize and distort images, and even create images on the fly.

Drawbacks:

- ◆ JavaScript is now only supported by Netscape 2.x and higher.
- ◆ Different versions of Web browsers may produce different results.
- ◆ There are some security holes in JavaScript
(<http://cgi.usma.edu/mirror/WWW/www-security-faq/wwwsf7.html#Q61>)

References for more information

- ◆ Netscape's JavaScript Authoring Guide
(<http://www.netscape.com/eng/mozilla/Gold/handbook/javascript/index.html>)
- ◆ JavaScript Index
(<http://www.sapphire.co.uk/javascript/index.html>)
- ◆ Gamelan Java Directory (<http://www.gamelan.com/>)

Implementation using Formula One/NET

Why did we choose this tool?

- ◆ Formula One enables Web browsers to read and write Excel worksheets. It allowed us to create a plug-in file from our existing Excel spreadsheet.
- ◆ With Formula One, Web applications get an Excel-like spreadsheet interface. Users can select cells and ranges, interactively copy and move ranges of data, automatically fill cells, resize rows and columns, just like Excel. Formula One provides support for 130 worksheet functions and the Excel-style formula syntax.
- ◆ Users don't need Excel on their desktop to run the Formula One-based application.

What restrictions are placed on the client?

The client needs a client side Web browser which supports plug-ins (such as Netscape 2.x or higher or Microsoft Internet Explorer 3.x). Also, the Formula One plug-in viewer must be downloaded and installed. So far, this plug-in is only available for Windows 95, NT, and 3.x without any UNIX or Macintosh versions.

What was the level of effort to implement? Summarize the implementation steps.

It took about an hour to install the Formula One/NET software and to convert an Excel spreadsheet into the Formula One format. Several days were spent fine-tuning the application.

Implementation steps:

1. Download the software from "<http://www.visualcomp.com/f1net/download.htm>" and install it.
2. Run the program. From the menu selection 'file/open', open an Excel file and save it as a Formula One plug-in source file which has extension .vts.
3. Embed the .vts files into the HTML page, and add "workbook/formulaone vts" to mime types of the Web server.
4. Start the Web browser and open this HTML page. The spread-

sheet should appear. If not, there may be a problem with the Web Server setup and you should check “<http://www.visualcomp.com/products/fo.htm>” for further advice regarding the specific Web server setup.

What did we learn about the concept / capability through implementation?

Formula One is easier to implement than Java or JavaScript and has more features for spreadsheet applications. On the other hand, Java and JavaScript do not require the client to use Web browser plug-ins and are languages which can be used for a wide variety of applications. Formula One is also not yet available for clients who use UNIX or Macintosh operating systems.

How might the concept / capability be employed for other applications?

Formula One can be used for any Excel spreadsheet application.

Benefits and drawbacks of the specific tool(s) used

Benefits:

- ◆ Easy to install and use.
- ◆ Robust user interface.

Drawbacks:

- ◆ It does not support Excel Macro.
- ◆ Requires a client-side plug-in. This plug-in is not available for UNIX or Macintosh browsers.
- ◆ Unlike JavaScript and Java, it can only develop Excel spreadsheet applications.

References for more information

- ◆ Formula One Page
(<http://www.visualcomp.com/products/fo.htm>)
- ◆ Formula One/NET FAQ
(<http://www.visualcomp.com/f1net/f1faqnet.htm>)
- ◆ Formula One/NET PRO
(<http://www.visualcomp.com/f1net/pro.htm>)

Concept Searching

What is it?

Because of the richness of language, a topic or idea can be described with a wide variety of words or expressions. For this reason, a conventional search may be too limited when you want to research a broad topic area. Concept searching enables users to search for information by concept rather than by keyword. For example, with a keyword query on ‘intellectual property rights’, the search software will return all those documents which explicitly mention one or all of those words. There may be other documents about intellectual property rights which don’t actually use those words — maybe they mention ‘software privacy’ or ‘copyright laws’, but never ‘intellectual’ or ‘property’ or ‘rights’. Concept searching could retrieve articles on software privacy and copyright laws even if those articles contained none of the original query words.

How does it work?

There are two ways to do concept searching:

1. Knowledgebase (Thesaurus) Approach. Using this approach, you need a knowledgebase. A knowledgebase is a dictionary of terms plus information about grammatical structures. The search software reads a text, transforming and comparing every word to its internalized knowledge, instantly cross-referencing every recognized idea among all the other (possibly related) ideas that it knows about, and generates the result.
2. Statistical Approach. The search software first generates a list of terms that are statistically related to the words in your query. Simply put, those words that have a significant degree of co-occurrence with your query words are deemed related within the context of the current database. After generating the aforementioned list, the concept search operation then performs a conventional search using the original query words as well as the related

terms. You will find that many of the records retrieved, while perhaps not having occurrences of your original query words, will nonetheless contain information that is relevant to your search interests.

Benefits and Drawbacks

Benefits

- ◆ A more “intuitive” search capability is provided. An information seeker does not have to be familiar with the exact language used within documents in order to find what is needed.

Drawbacks

- ◆ For the knowledgebase approach, developing a thesaurus is an intensive, time-consuming task.
- ◆ For the statistical approach, the returned documents will not be relevant in all cases.

URLs where demonstrated

- ◆ Universal Interface Evaluation Search
(<http://www.ctg.albany.edu/projects/inettb/univ/EWS/AT-Reportquery.html>)
- ◆ Excite Netsearch (<http://www.excite.com/>)
- ◆ Search www.sun.com (<http://www.sun.com/search/search.html>)
- ◆ Adobe Technical Database (<http://www.adobe.com/supportservice/custsupport/tssearchdb.html>)

Implementation Details

Describe the application where this concept / capability was used

(<http://www.ctg.albany.edu/projects/inettb/univ/EWS/AT-Reportquery.html>)

It was used to search the Universal Interface Testbed prototype evaluations.

What tool(s) were used and where did we find these tool(s)?

Excite for WebServers (EWS) (<http://www.atext.com/>)

What other tools are out there which do the same thing?

- ◆ CSQuest (<http://ai.bpa.arizona.edu/cgi-bin/mcsquest>)
CSQuest is a concept-based search tool developed by the AI Group in the Management Information Systems Department at the University of Arizona.
- ◆ ConSearch (<http://www.imsworld.com/miti/order.html>)
ConSearch is an electronic document and file access utility developed by Management Information Technologies, Inc.

Why did we choose this tool?

- ◆ EWS is fast, easy, and free for use.
- ◆ EWS can do concept searching and keyword searching. You can choose which method you want to use.
- ◆ There are more than 100 web sites using EWS including Netscape, SUN, Adobe, AOL, Chevron and United Airlines.
- ◆ The quality of EWS search results are good. Internet World[1] labs tested seven internet search tools. They found the keyword search results of EWS was almost as good as #1 rated Infoseek Guide at understanding phrases and finding relevant information.

What restrictions are placed on the client?

No restrictions.

What was the level of effort to implement? Summarize the implementation steps.

It was easy to implement, taking only a few hours. Specific steps were:

1. Download EWS
Go to <http://www.excite.com/navigate/download.cgi> select your operating system type and then download the EWS archive.
2. Install EWS
Installation was simple, fast, and straightforward.
3. Configuration
Configuration was also simple. Create a “Document Collection”, configure it’s attributes, and index the document collection. A document collection is the searchable set of documents.

What did we learn about the concept / capability through implementation?

Knowledgebased concept searching needs a thesaurus: it requires expertise in a particular topic area and may be difficult to maintain; but it is also more accurate and it will not be affected by document layout; the statistical approach is easier to implement and maintain.

How might the concept / capability be employed for other applications?

Currently, any applications which need to do “text searching” and not “field-based searching” can use the concept searching tool. Products are expected on the market soon which can do both concept searching and field-based searching.

How does it contrast to other methods for doing the same thing?

Keyword searches are limited to exact word-for-word matches in the text of a document. Knowledgebased systems can do concept searching, but they need to be developed by experts in a particular field in order to develop the thesaurus.

Benefits and drawbacks of the specific tool(s) used.

Benefits:

- ◆ It is free.
- ◆ It is easy to install and configure.
- ◆ It can do keyword searching and concept searching.
- ◆ The EWS runs on Windows NT and a variety of UNIX platforms.
- ◆ It supports multiple document formats, including plain ASCII, SGML, HTML, RTF, PostScript, and others. In addition to supporting multiple text formats, the EWS allows users to retrieve arbitrary data types (such as sound, images, or video) associated with the text.
- ◆ The engine can be applied to any language.

Drawbacks:

- ◆ The document summaries generated do not always represent the text accurately.
- ◆ Excite's search results could not be stored as a bookmark.
- ◆ If the documents being searched use the same layout, it will return "matching" documents based on layout instead of content.
- ◆ The results from the keyword search are not completely included in the results from concept search.
- ◆ The optional maintenance support on EWS 1.0 is \$995 per server per year.
- ◆ EWS cannot currently do field searching like FreeWAIS-sf [6].

References for more information

- ◆ Search Engine Showdown, Internet World Magazine, May 1996, pages 79-86.
- ◆ Add an Engine, Internet World Magazine, May 1996, pages 88-92.
- ◆ CSQuest (<http://ai.bpa.arizona.edu/cgi-bin/mcsquest>)
- ◆ ConSearch (<http://www.imsworld.com/miti/order.html>)
- ◆ Excite for WebServers (<http://www.atext.com/>)
- ◆ FreeWAIS-sf (<http://ls6-www.informatik.uni-dortmund.de/ir/projects/freeWAIS-sf/index.html>)

Cookies

What is it?

Cookies allow a Web server application to gather information about a client and store that information in a file right on the client's machine. Once the information is stored, the client will continue to send that same information (called a "cookie") to the server each time a connection is made.

Cookies are used to track information from one Web page to another. This becomes useful in such applications as shopping cart catalogues, where a customer might choose items on one Web page and then advance to another page in the catalogue to buy additional items. The cookie can keep track of the items as the customer shops and then tally up the order at the end of the shopping spree. Since information is usually lost as one Web page is replaced by another, the cookie is a powerful tool for tying together an application which must use multiple pages.

Personal information pages are another type of application enabled by cookies. These pages allow users to choose their own areas of interest. The preferences are stored in a cookie file on the user's machine and are sent to the server application each time a connection is made. The application then creates and sends to the user a "personal info page" based on these preferences.

How does it work?

While on the Web, a client fills out a form and sends it to the Web site. This form may contain information that the Web site wants to keep for future use. The Web site sends back a Web page to the client in response. This Web page contains HTML code which instructs the client's Web browser to write the desired information on the client's hard disk into a file known as the cookie file. The next time the client visits the same site, the information in the cookie file will automatically be sent to the server.

Benefits and Drawbacks

Benefits

- ◆ Interactions between a Web browser and a Web server are "stateless." This means that once information is transmitted between client and server, the connection between them ends. For example, when a client enters a URL, a request is made to a Web server; the Web server then sends the desired page to the client and the connection ends. When a client sends a form to the Web server, the server side programs send back a Web page in response and the connection ends. There is no built-in mechanism which allows a program on the server side to store information about the client as interactions take place over several Web pages or over time.
- ◆ Cookies allow the server side programs to store small amounts of information about the client from session to session. This allows new types of applications to be written for web-based environments. Shopping cart applications can track an individual's order as he or she moves from Web page to Web page. Personalized information pages can ask about an individual's likes and dislikes and then tailor responses to that individual's preferences.
- ◆ Registered services can store the user's registration information, freeing the individual from entering it each and every time.

Drawbacks

- ◆ Sometimes the individual does not realize that information is being saved for future use and there may be an issue of privacy. Netscape 3.0 offers an alert box to let users know whenever a request is made to write cookie information on a user's hard-drive. The user is then given the option to proceed or not. This alert box can be turned on or off.
- ◆ Most browsers support cookies (such as Netscape, MOSAIC, and MS Internet Explorer), but not all do.
- ◆ Cookie programming generally requires knowledge of the cookie specification, the Common Gateway Interface Standard, and a programming or scripting language (such as PERL or C).

URLs where demonstrated

- ◆ Kid's Personal Info Page
(<http://www.ctg.albany.edu/projects/inettb/univ/kidinfo>),
described below.
- ◆ Netscape's General Store
(<http://merchant.netscape.com/netstore/index.html>)
- ◆ "Excite Live!" personal magazine (<http://live.excite.com/>)

Implementation Details

Describe the application where this concept / capability was used.

(<http://www.ctg.albany.edu/projects/inettb/univ/kidinfo>)

Cookies were used to create a personal information page for children. The child enters specific areas of interest and the information page is created with links to those topics. On subsequent visits to the site, the child's preferences continue to be reflected in the personalized page.

What tool(s) were used and where did we find these tool(s)?

- ◆ Perl Script (<http://www.perl.com/perl/faq/>)
- ◆ Common Gateway Interface Standard
(<http://hoohoo.ncsa.uiuc.edu/cgi/overview.html>)
- ◆ Netscape: Client Side State - HTTP Cookies Specification
(http://home.netscape.com/newsref/std/cookie_spec.html)

What other tools are out there which do the same thing?

Cookie implementations can also be done with Java and JavaScripting instead of with CGI scripts. Information on these can be found at Gamelan (<http://www.gamelan.com>).

Why did we choose these tools?

Perl and CGI programming were chosen over Java or JavaScripting since there was more information and more sample programs using this method at the time of implementation.

What restrictions are placed on the client?

The client must have a browser which supports cookies. Netscape, MS Internet Explorer, and MOSAIC are the most popular browsers and they each support cookies.

What was the level of effort to implement? Summarize the implementation steps.

The programming required a good understanding of both the Common Gateway Interface Standard and the Cookie Specification as well as experience with the particular programming language used. It took about three weeks to implement and much of the specifics about how cookies really work was obtained by trial and error.

Implementation was achieved by creating a CGI Script which will be executed every time a connection is made to URL <http://www.ctg.albany.edu/projects/inettb/univ/kidinfo> . The CGI script performs the following functions:

If there is no "cookie" established for this user: Send a Web input form which will ask the user to select preferred areas of interest. When submitted, the above CGI script will dynamically create a personalized information page and send it to the user; that information page will contain html code which instructs the Web browser to store those preferences in a cookie file.

If there is "cookie" information already established: The CGI script will read the cookie information, dynamically create a personalized information page, and send it to the user.

The source code for kidinfo.cgi can be found at <http://www.ctg.albany.edu/projects/inettb/univ/kidinfo/kidinfo.src>

What did we learn about the concept / capability through implementation?

The theory of cookies is sometimes more straightforward than the implementation. The HTML code which instructs the browser to store cookie information needs to be very precise and the various browsers have slightly different expectations and methods for implementing. A helpful listing of implementation tips can be found at "Andy's Tasty HTTP Cookie Tidbits" (http://www.illuminatus.com/cookie_pages/tidbits.html).

How might the concept / capability be employed for other applications?

Cookies can be employed for any application which needs to save small amounts of information supplied by the client without saving that information in a database on the server. A database may not be appropriate because the information is temporary in nature (such as in the case of tracking a list of purchases through a shopping cart order) or because the cost of a full database is not warranted (such as in the case of personalized info pages).

How does it contrast to other methods for doing the same thing?

Applications which employ server side databases can also save information from session to session but are much costlier in terms of price, complexity, application development time, administration, and hardware requirements. Saving information in cookie files stored on the client makes sense for many situations where small amounts of information (up to 255 characters) are all that is needed.

Benefits and drawbacks of the specific tool(s) used.

Benefits:

- ◆ Perl Script is an easy language to learn and use.

Drawbacks:

- ◆ The CGI program should be written by an experienced programmer.

- ◆ CGI scripts are vulnerable to security problems and these need to be understood so that the coding protects against break-ins.

References for more information

- ◆ Netscape: Client Side State - HTTP Cookies
(http://home.netscape.com/newsref/std/cookie_spec.html)
- ◆ Andy's HTTP Cookie Notes
(<http://www.illuminatus.com/cookie.fcgi>)
- ◆ Malcolm's Guide to Persistent Cookies
(<http://www.emf.net/~mal/cookiesinfo.html>)

Streaming Technology

What is it?

Streaming technology allows a Web client to access information in a file stored on the server before that file is completely downloaded. This means that large multimedia files (such as for a one hour speech) can be heard or seen almost immediately, even with slower connections. This capability provides what is commonly known as audio-on-demand (or video-on-demand). It allows for the “broadcast” of previously stored presentations as well as for the broadcast of live events.

How does it work?

The multimedia file is sent from the server to the client in a stream of transmissions. As each piece of the file is received, it is saved in a buffer on the local machine. Once a minimal amount of information has been buffered, the file can begin to be played on the client machine.

At the current time, there are no standard protocols for streaming files over the World Wide Web, so different companies implement this technology in slightly different ways. Some streaming products (such as RealAudio) require a special server to be employed in addition to the Web server. Others (such as True Speech) use the standard Web server to stream the file. In all cases, a Web browser plug-in program is required on the client side in order to play the file.

Benefits and Drawbacks

Benefits

- ◆ Allows large multimedia files to be played over the Internet almost immediately.
- ◆ Provides the ability to fast-forward or reverse through multimedia presentations.

- ◆ The required browser plug-in programs for playing streamed files have been incorporated into the newer versions of some browsers (such as Netscape 3.0), making the technology “transparent” to the user.

Drawbacks

- ◆ With a 14.4 kbps connection, only audio streaming is recommended for smooth, realistic playback. With 28.8 kbps connectivity, pictures can be sent along with the audio. Video streaming generally requires much faster connections.
- ◆ Creating the files needed for streamed transmission is a time-consuming task.
- ◆ The formats employed in streaming technology are usually proprietary (not open standard). Each format requires its own plug-in program. A plug-in from one company cannot play the file format of another company.

URLs where demonstrated

- ◆ Internet Security Seminar (<http://www.ctg.albany.edu/projects/inettb/security.html>), described below.
- ◆ ESPN Sportszone (<http://espnet.sportszone.com/editors/liveaudio/archive.html>)
- ◆ Timecast (<http://www.timecast.com/>)
- ◆ Cool Sites Using True Speech (<http://www.dspg.com/cool.htm>)

Implementation Details

Describe the application where this concept / capability was used.

<http://www.ctg.albany.edu/projects/inettb/security.html>

A seminar on Internet security was presented by the Center for Technology in Government in conjunction with corporate and public sector partners. Using streaming technology, the full presentations can be heard at the same time as the overheads are viewed.

What tool(s) were used and where did we find these tool(s)?

Real Audio was used. This product can be downloaded from <http://www.realaudio.com>

What other tools are out there which do the same thing?

- ◆ Xing Streamworks (<http://www.xingtech.com>)
Xing Streamworks support real-time MPEG video and audio on demand developed by the Xing Technology Corporation.
- ◆ TrueSpeech (<http://www.dspg.com>)
True Speech is the Digital Speech Products Group's competitive answer to Real Audio developed by the DSP Group, Inc.
- ◆ Internet Wave (<http://www.vocaltec.com/iwave.htm>)
Internet Wave is the official debut of VocalTec's real-time audio on demand application developed by VocalTec.
- ◆ VDOLive (<http://www.VDOLive.com>)
VDOLive is a multimedia viewer for playing real-time audio and video files developed by VDOnet Corp.

Why did we choose this tool?

RealAudio is currently one of the most popular real-time audio products. It provides very stable and high quality audio.

What restrictions are placed on the client?

1. The client machine must have a sound card.
2. The client must have the RealAudio player installed.

What was the level of effort to implement? Summarize the implementation steps.

RealAudio Server Setup:

It takes about two to three days to understand the structure and installation of the RealAudio Server. Then, it takes one more day to encode the original audio file to the RealAudio file format and get

acquainted with the RealAudio Player.

Specific steps for implementation included:

1. Download and install the RealAudio server.
2. Encode the sound files to RealAudio format.
3. Create metafiles (files with a .ram extension) to describe the characteristics of the sound files.
4. Insert the metafile links into the HTML documents.

What did we learn about the concept / capability through implementation?

It was possible to integrate images with speech, but a 28.8 kbps connection was necessary for the effective streaming of both simultaneously.

How might the concept / capability be employed for other applications?

Streaming technology can be widely employed for broadcasting services, seminar demonstrations, tour guides, computer aided instruction, etc.

How does it contrast to other methods for doing the same thing?

Prior to streaming, files had to be downloaded completely before they could be used. This meant that multimedia files delivered over the Web had to be kept very small. Most audio files delivered using more traditional formats, for example, are under 3 minutes in length.

Benefits and drawbacks for the specific tool used

Benefits:

- ◆ RealAudio supports many kinds of platform such as Windows 3.x, 95, NT, SUN OS, SUN Solaris, and IRIX, etc.
- ◆ The Web Server and RealAudio Server are independent, so they can be located on different machines.

- ◆ The RealAudio Server features Bandwidth Negotiation which allows RealAudio Players to receive optimal sound quality based on their connection speed. That is, the RealAudio Server automatically detects the connection speed of the RealAudio Player and chooses which RealAudio file should be sent.
- ◆ RealAudio compresses audio files efficiently. For example, using 8kHz/8bit/Mono rate to record a one hour hour speech used 28Mb of space using the traditional .wav format, but only used 3.6Mb using the RealAudio format.

Drawbacks:

- ◆ RealAudio's audio format is proprietary (not an open standard).
- ◆ RealAudio can deliver audio and pictures, but not video.
- ◆ It is time-consuming to encode original audio files (.wav or .au) to RealAudio files (.ra).

References for more information

- ◆ The RealAudio Features, detailed Documents and FAQ:
<http://www.realaudio.com/products/ra2.0/index.html#features>
<http://www.realaudio.com/help>
- ◆ Streamworks Features and FAQ:
http://www.xingtech.com/sw_now.html
http://www.xingtech.com/technical_support/swplayer.html
- ◆ True Speech Features, Benefits, and FAQ:
<http://www.dspg.com/internet.htm>
<http://www.dspg.com/benefits.htm>
<http://www.dspg.com/tsfaqs.htm>
- ◆ Internet Wave Press Release, Installation, and Benefits:
<http://www.vocaltec.com/iwpress.htm>
<http://www.vocaltec.com/iwave.htm#what>
<http://www.vocaltec.com/green.htm>
- ◆ VDOLive Technical Support and Manuals:
<http://www.vdo.net/tech/>
<http://www.vdo.net/tech/manuals>

Virtual Reality Modeling Language (VRML)

What is it?

VRML (Virtual Reality Modeling Language) is a platform-independent file format for sharing 3D worlds on the Web. VRML worlds can be interactive and animated, and can include embedded hyperlinks to other Web documents.

Virtual reality literally adds a “new dimension” to information dissemination. Interactive, 3-dimensional models can enhance collaborative discussions in such areas as chemistry, architecture, medicine, geography, and engineering. Perhaps more importantly, virtual reality can create an interface with the user which simulates the real world and thus has the potential to create a more natural way for people to navigate through the Internet.

How does it work?

The VRML standard provides a specification describing the file format, specifically for VRML browsers and authoring tools- it is analogous to the HTML standards for text and graphics on World Wide Web pages, since it has been adopted as a (the) 3-D file format for the Web.

Benefits and Drawbacks

Benefits

VRML is the most common 3-D file format seen on the Web for virtual environments. This means that all the major Web browsers will recognize the file format and will either display in-line or with a helper application, the 3-D VRML objects. Another benefit is that SGI has developed a whole suite of tools under the COSMO name for programming, authoring, creation, editing, and playback (or viewing) of VRML and HTML; also, most better CAD/Solid Modelers today (Pro/ENGINEER, I-DEAS, Catia, CADDSS,

Unigraphics, etc.) will export out an Inventor file, which is a subset 3-D format of VRML; CAD models can become VRML models available for retrieval over the Web by fellow engineers for design review, right within a Web-based application like Netscape.

Drawbacks

VRML doesn't contain mass properties or sufficient absolute dimensional information to take a VRML model and reconstruct it back into a CAD system, this can be done with widely varying degrees of success with DXF and IGES file formats.

URLs where demonstrated

- ◆ Silicon Graphics VRML Gallery: <http://vrml.sgi.com/intro.html>
- ◆ NCSA Relativity Group VRML Page: http://jean_luc.ncsa.uiuc.edu/viz/VRML
- ◆ The National Center for Supercomputing Applications: <http://www.ncsa.uiuc.edu/General/VRML/VRMLHome.html>
- ◆ VRML Repository at SDSC: <http://www.sdsc.edu/vrml/repository.html>
- ◆ Template Graphics Software: <http://www.cts.com/~template/>
- ◆ Webmaster Resources: http://www.cio.com/WebMaster/wm_notes.html#vrml

Implementation Details

Describe the application where this concept / capability was used

3-D engineering models generated from CAD systems were converted to VRML. Annotations were attached to the models in the form of

arrows pointing to specific physical features and these arrows were linked to other files. Clicking on an arrow brings up a text, a 2-D picture, sound, or a movie file. The file is downloaded and played back using the appropriate application, conveying engineering information about the 3-D model.

What tool(s) were used and where did we find these tool(s)?

Webspace Author, CosmoCreate3D, and CosmoWorlds were used to import the CAD model and create the 3-d arrows and links. Webspace and CosmoPlayer were the VRML plug-ins used to view the model. These can all be downloaded from the Silicon Graphics site (<http://www.sgi.com>).

What other tools are out there which do the same thing?

See <http://www.dur.ac.uk/~dcs3py/pages/work/Documents/VR-Survey/index.html>.

Why did we choose this tool?

SGI bundles them with their systems.

What restrictions are placed on the client?

The client machine must have a VRML compliant Web browser, or a browser which is capable of recognizing the VRML file type and of launching the appropriate viewer. The latest version of Netscape, 3.0, will view VRML right in the Netscape window without the need for a plug-in. Older versions of Netscape, as well as MS Internet Explorer 3.0, require the plug-in, which is downloadable off the Web from Netscape.

What was the level of effort to implement? Summarize the implementation steps.

The VRML programs were installed. Time was then spent becoming familiar with the tools, through online documentation and through hands-on demos. It took approximately three days to understand the tools well enough to work with them. It can take one to two months to become proficient.

Although a good authoring tool will eliminate the need to know the details of the VRML 2.0 specification, proficient VRML 2.0 authors are familiar with the Nodes and Fields so they can take full advantage of the capabilities of VRML 2.0

VRML 2.0 Nodes (New from VRML 1.0). VRML 1.0 allowed content developers to create static 3D worlds which contained links to web content. VRML 2.0 builds on the geometric foundation of VRML 1.0 with the addition of three basic concepts: sensors, scripts and sound.

Sensors - Interaction with the User. Sensors provide mechanisms for the user to interact with objects in the world. Functionally, they generate events based on time or user action.

What did we learn about the concept/capability through implementation?

Virtual reality can enhance communications in many professional areas.

How might the concept/capability be employed for other applications?

The idea of annotating 3-D models for collaborative discussion over the Web has applications in chemistry, architecture, medicine, geography—almost anywhere that a 3-D object or world with detailed information about it needs to be shared with other people.

How does it contrast to other methods for doing the same thing?

From the perspective of an engineer or designer, the more common way of discussing designs is to print out a 2-D drawing of the part or assembly, mark it up, and forward it to the other parties, often by mail, it is very time consuming and subject to errors in interpretation. Another way designs are collaboratively reviewed is with video-teleconferencing with electronic whiteboard systems; these are excellent tools, but are quite expensive and don't share a Web-based interface.

Benefits and drawbacks for the specific tool(s) used.

Benefits:

The VRML authoring tools discussed have ever-richer feature sets and can now do things that were, until very recently, the domain of expensive specialized modeling softwares.

Drawbacks:

The drawback is that they are just out of Beta stage, and could use a little more time for the level of robustness needed for commercial use.

References for more information

- ◆ The National Center for Supercomputing Applications
(<http://www.ncsa.uiuc.edu/General/VRML/VRMLHome.html>)
- ◆ Netscape: An Introduction to VRML
(http://home.netscape.com/comprod/products/navigator/live3d/intro_vrml.html)
- ◆ The VRML specification
(<http://vrml.sgi.com/moving-worlds/spec/index.html>)
- ◆ VRML demos (<http://vrml.sgi.com/worlds/vrml2.html>)
- ◆ Other references: (<http://vrml.sgi.com/worlds/other.html>)

Chapter 3. Business Applications

Overview

Many organizations are seeking ways to take advantage of the World Wide Web client/server architecture in order to enhance the functionality and efficiency of core business processes. While this service area has shown itself to be the most complex and the most expensive to implement, it is also the area with the largest potential payback. The open standards employed by the Internet, the universal interface offered by the World Wide Web, and the public nature of the underlying network combine to offer striking advantages over traditional computerized business applications. Our case studies for this project, along with a review of best practices in this arena, have highlighted a number of these benefits:

- ◆ **Improved Access at a Reduced Cost.** The Internet is a public network, offering ubiquitous access to information and services. This access allows outreach to large categories of people who could never have access to more traditional business systems: those working at home, collaborators from other organizations, staff who travel and work at continually changing locations, and the general public. Access is made available to these individuals 24 hours a day, seven days a week, on all major platforms.

In addition to improving outreach, Internet access costs are far less expensive than using private networks and leased lines. With the use of cryptography and other security measures¹, even private transactions can be offered over this public network. One study has indicated that using the Internet as a secure pipeline can result in savings of 23% to 50% over the use of leased lines².

- ◆ **A User-Friendly Interface.** The World Wide Web interface is graphical, intuitive, and already understood by a large number of people who may be participating in the business process. This advantage alone often justifies the move to Web-based applications. Learning curves are reduced, training expenses are slashed, and higher participation is ensured as the comfort level of the audience is increased.
- ◆ **Ability to Streamline the Business Process.** With improved access and a more user-friendly interface comes the ability to reduce the

middle layers of a business process so that the entire operation is streamlined. For example, a middle layer in an organization may be responsible for collecting business information from others, formatting and entering that data on a computer application to which only they have access (or which only they understand), and then distributing reports to others once processing has been completed. Under a Web-based model, information can be entered by the individuals actually conducting the business. As an example, employees could enter their purchase requisitions or travel expenses directly into the business application using a Web interface. Managers could enter their proposed budgets. Students could apply to colleges or register for courses. These individuals can also have immediate and direct access to the information they need from the organization to carry out their work. This streamlined approach can result in cost reductions, a decrease in errors, and more immediate input of, and access to, important business information.

- ◆ Ability to Integrate Diverse Systems. Since the World Wide Web uses open standards for communicating information, it can often serve as a force for integrating multiple applications running on multiple platforms. Middleware applications can pull data from multiple back-end systems and combine that information into a single Web presentation. Information entered on a Web page can be distributed back to these multiple systems as well. As one example, an entrepreneur beginning a new business could find start-up requirements from several state agencies in a unified Web presentation. This entrepreneur could then fill out a single form and have the information from that form distributed to the back-end systems of those same agencies. Such integration could have dramatic impact on the quality of service delivery to consumers and could also improve the coordination and effectiveness of each participating agency.
- ◆ Shifts Processing Away From Expensive Mainframes. Web-based solutions allow processing to be shifted away from the mainframe onto less expensive machines. In some cases, an entire mainframe application can be replaced by a system running on lower priced servers and workstations. In other cases, a mainframe application can have part of its process (such as the user presentation and/or transaction editing) replaced by the Web-based front-end. The result can mean significant savings and/or greater longevity for the existing legacy system.

Costs and Payback

The following table, provided by Gartner Group, illustrates the escalating costs associated with more advanced uses of the Web.

Point of Presence: <i>To be present on the Web</i>
Advertising: <i>Information dissemination about programs, products, services</i>
Marketing and Sales: <i>Outreach through the Web for new customers</i>
Distribution Channel: <i>Distribution of software and various information products such as articles & books</i>

Typical Overall Web Site Implementation Costs			
Site Objective	Low	Average	High
Point of Presence	\$20,000	\$65,000	\$75,000
Advertising	\$250,000	\$300,000	\$350,000
Sales/Marketing	\$400,000	\$500,000	\$700,000
Distribution	\$1,000,000	\$1,500,000	\$3,000,000

Despite the fact that greater complexity generates higher costs, Gartner concluded that the payback period actually declines as the site complexity increases. Based on client feedback, this payback period was estimated to average only 10 months for the Distribution sites.³ Payback was measured in reduced advertising costs, increased sales, and decreased distribution costs.

Web / Legacy Implementation Strategies

Fortunately, there are a variety of choices for incorporating the Web into existing business applications. These range from complete redevelopment of a mainframe application onto a more Web-accessible platform to real-time Web server interaction with mainframe legacy systems.

When replacing a mainframe application, it is often desirable to migrate from the legacy application to the Web-based application in stages. Steps for achieving this migration can include any or all of the following:

- ◆ Copying of mainframe data onto a Web-accessible database in batch mode. For example, data can be retrieved from the mainframe on an overnight (or hourly) basis and reorganized on a Web-accessible database to be available over the Internet. At this stage, Web access to the new database is limited and often mimics the mainframe access.

- ◆ Gradual rewriting of the user interfaces to the new database in order to take advantage of the Web architecture. These improvements can begin with Web pages providing enhanced information retrieval, such as self-directed searches, and then progress to Web-based data entry and updating.
- ◆ A shift from using the mainframe database as the primary system to using the server database as the primary system. During this stage, the Web system drives the business process and data is transported to the mainframe on a regular basis in order to print reports or to interface with other mainframe systems.
- ◆ Total replacement of the mainframe system with the Web-based system. All functionality is now incorporated into the new system.

There are also a variety of approaches available for real-time access to mainframe legacy applications. More solutions are being made available every day as software companies react to increasing demand. A typical solution might consist of the following components:

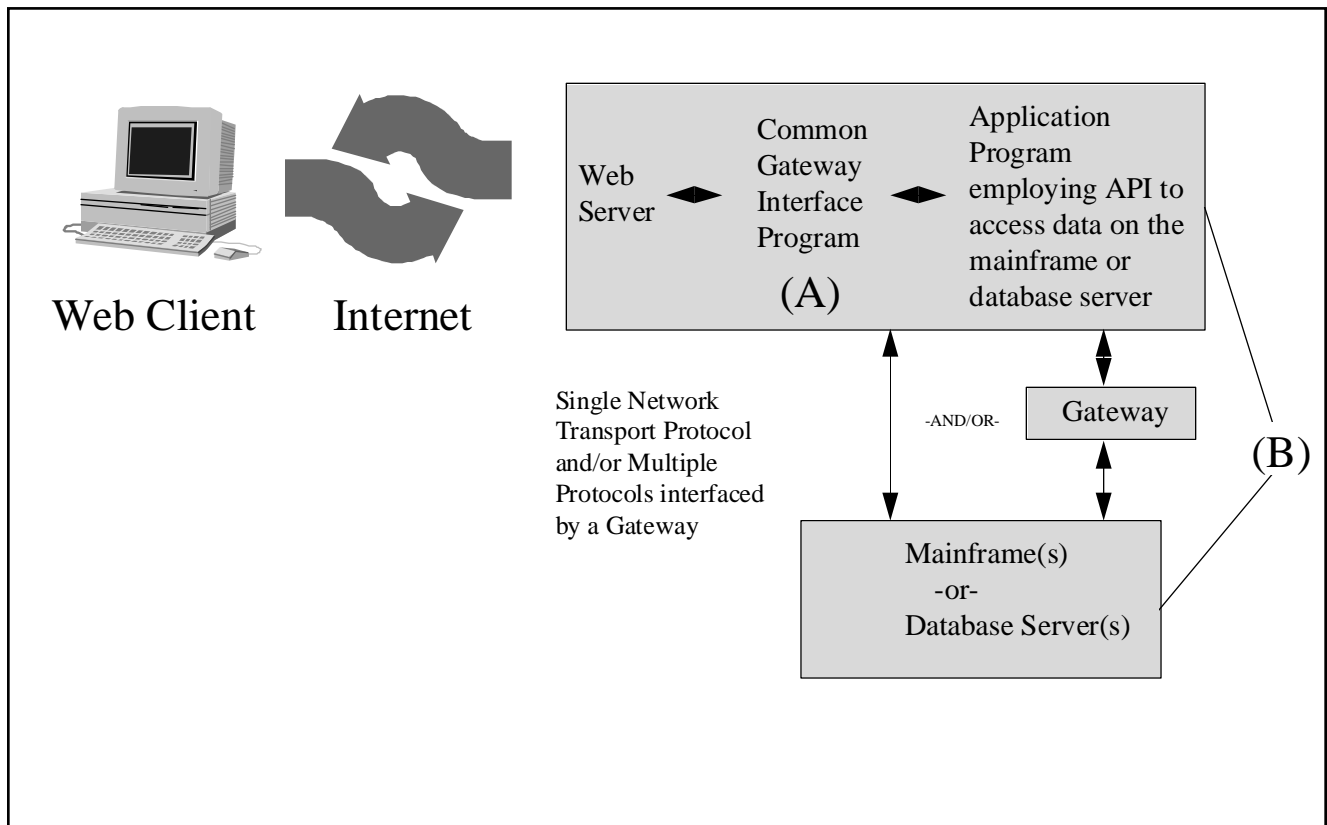

The Common Gateway Interface (A)

Common Gateway Interface programs are used to process the input submitted by a Web client using an HTML form. When a form is submitted to the Web server, the server calls the CGI program which has been identified within the HTML code of the form. Input from the form is then made available to the CGI program using the Common Gateway Interface Standard. The CGI program can process the input data itself or call on other programs such as database or mainframe interfaces. Thus, information submitted by the form can interact with legacy applications. The CGI program can also dynamically create HTML pages to be passed back to the client. A database search could be conducted using the input fields, for example, and the results passed back to the user in a dynamically generated Web page.

Access to the Mainframe (B)

Popular access methods from the Web server machine to a mainframe include the following:

- ◆ Direct Access to a single mainframe application. Legacy applications come with a variety of mechanisms for tapping into their data. These generally involve software which sits on both the mainframe and the Web server machine, each communicating with the other over an acceptable network transport protocol. Popular access methods include:
 - ◆ SQL - This is the 'Standard Query Language' adopted by most relational databases. Although this is considered a 'standard,' each proprietary database usually has its own slightly different version of the SQL implementation. Application programming interfaces (APIs) are made available by the software companies so that SQL communication can be implemented as a called procedure from applications written in a variety of programming languages.
 - ◆ ODBC - This is a flavor of SQL initiated by Microsoft. It is more generic than the proprietary SQLs identified above, but it is also generally slower. Thus, greater flexibility is traded for reduced response time. Depending on the expected transaction volume, the slower times may not be noticeable to the average user.
 - ◆ 3270 Terminal Emulation - This method is often used for CICS¹ applications. Here, APIs are made available which allow an application sitting on the server to act like a "dumb

terminal” connected to the mainframe. The application is able to send keyboard strokes to the mainframe (thus executing transactions) and then read the output generated by the CICS application (usually displayed on a terminal screen, but now delivered to the application). This approach is also referred to as “screen scraping.”

- ◆ **Other Proprietary Methods** - A variety of additional access methods exist for the various mainframe application platforms. These can be supplied by the primary vendor or by third parties.
- ◆ **Synchronization of access to multiple applications.** The access methods identified above can be used to connect to more than one application. In this case, it may be necessary to ensure that all updates to mainframe systems are “in synch.” Methods such as two-phase commit, recovery, and rollback are often employed. The basic idea behind these mechanisms is simply to ensure that all files are updated simultaneously or the transaction does not take place.
- ◆ **Replication of data.** When the legacy data is originating from remote sites and/or involves complicated data structures, it may be desirable to pull selected fields from each remote system and replicate them on a new integrated database. This replication can provide a simpler view of the data, making application development quicker and less prone to error. Synchronization is then employed to update the back-end systems on a timed or trigger-dependent basis.

Practical Results

Two case studies are presented which demonstrate practical solutions to the goals of Web/Legacy System integration. The first study summarizes the experiences of migrating a large scale, mainframe-based, legacy application (America’s Job Bank) to a World Wide Web based architecture. The second case study reviews the prototype implementation developed at SUNY System Administration for implementing real-time connectivity from the Web server to the mainframe Purchasing Card System.

¹ For an overview of issues related to Internet Security, see the CTG Security Seminar at <http://www.ctg.albany.edu/projects/inettb/security.html>.

² Sun Microsystems, Internet-based SVPNs: The Cost of Ownership [online], available at <http://www.incog.com/execsumm.html>.

³ Gartner Group, Calculating Payback on Web Marketing Projects, July 22, 1996.

Case Study of America's Job Bank: Bringing a Legacy System to the Internet

© 1996
Denis J. Martin
NYSERNet, Inc.

Abstract

America's Job Bank (AJB) is a program of the United States Department of Labor and the various State Employment Security Agencies. Its objective is to collect and disseminate job information nationally in an effort to increase the awareness of available jobs by those seeking employment. The national AJB system involves many different state level systems and applications, with overall coordination provided by AJB staff.

AJB has existed for over 10 years. Its primary methods of collecting and disseminating job information is through a batch collection process and an online CICS¹ application. In the summer of 1994, AJB set out to bring its application and associated databases to the Internet. This section describes the initial implementation process and developments since that time. It outlines the challenges faced when trying to move a complex legacy system to the Internet. In particular, it looks at a mainframe-based collection/processing/distribution system comprised of:

- ◆ input from, and output to, multiple local sites running on various platforms
- ◆ local systems using parochial applications
- ◆ reliance on a centralized batch process to manage data mapping and transformation between the local systems and the national system.

Phases of the AJB Web implementation include:

- ◆ replication of the central mainframe system to an RS/6000 server
- ◆ the addition of new options and features to the replicated system
- ◆ re-writing of the RS/6000 system to take advantage of Web architecture
- ◆ a strategic re-engineering plan aimed at migrating the existing batch process wholly to the Web-based system.

The strategic plan represents the final phase of this project's solution to bringing the multi-site legacy system to the Internet. The plan moves AJB away from current methods of collecting, processing, and distributing data to a new national system based on the Internet and its standard applications and protocols. A client/server - agent/server architecture is proposed to provide a system of coordinated servers and/or databases for providing integration between state level systems and the national system.

Background

This section describes the current status of the AJB system. The system's future strategy, subsequently discussed, is built on this base.

Existing Mainframe-Based System

The current mainframe-based system uses a RJE/NJE² network and tapes to collect information from states. The simplified general process flow is:

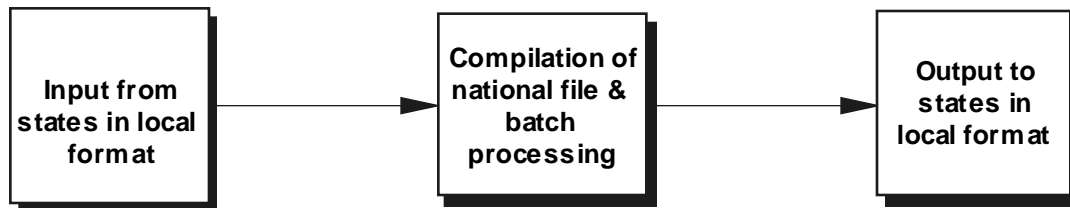

This is a simplification of the many complexities of the existing system. However, it does describe the overall architecture of the system at a high level. Files are sent to the AJB service center via RJE/NJE protocols and tapes. State level data is transmitted in local format and AJB processing converts the state data from the local format to that required for the national AJB file and application. In addition to being returned to the states in local format, the compiled data is used for several applications. These include the mainframe and PC Automated Labor Exchange (ALEX) systems and WebAJB, which is the current World Wide Web implementation of America's Job Bank (<http://www.ajb.dni.us>).

In addition to this primary process, there are many related sub-systems that are driven from the base data. Included among these is a method for tracking referrals, with information passed from the state to the national system and then distributed back to the state after processing.

Current Internet Implementation

The current implementation of AJB on the Internet is comprised of several components, represented by the diagram below:

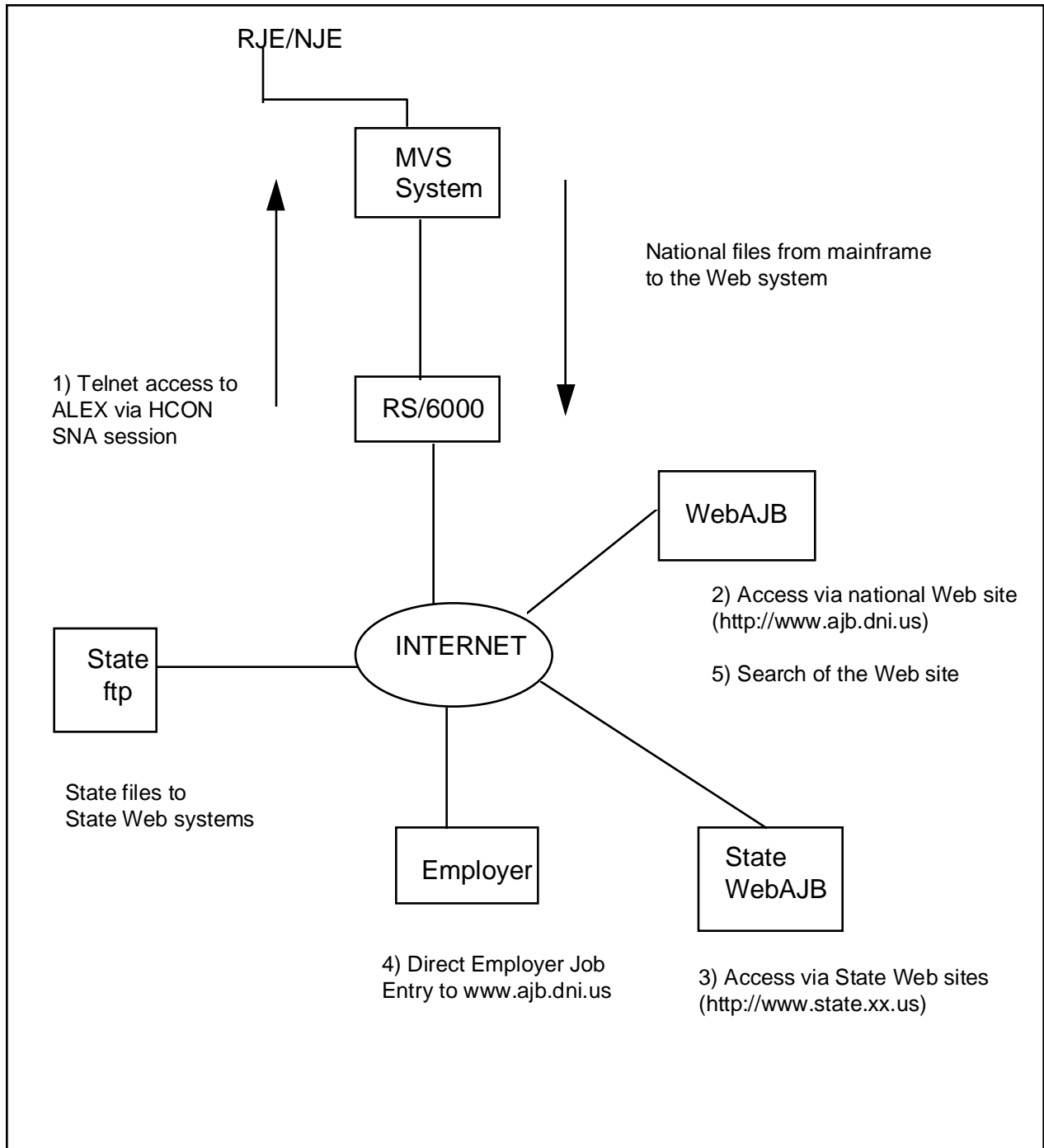

- 1) Access to the legacy mainframe application is provided through telnet to an RS/6000 AIX³ system, which in turn has custom programming to support establishing an SNA⁴ session to CICS on the mainframe's MVS⁵ system to logon to mainframe ALEX. Telnet access to the AIX system is via standard telnet server functions provided by AIX. SNA access is provided by HCON⁶ which is installed on the AIX system providing 327X terminal session to CICS. Custom programs written in C and Perl running on the AIX system link telnet users to SNA sessions. Custom programs run under the AIX operating system on the RS/6000.
- 2) Access to AJB data is also provided through the World Wide Web. The address for the WebAJB system is <http://www.ajb.dni.us>. In the first phase, this system was built by porting the PC ALEX code to a Unix platform. The platform used for the initial port is the BSD/OS operating system running on an Intel Pentium platform. The Web server was constructed with customer comment forms, and informational and referral sections. The bulk of the initial Web system, though, was a replication of the self directed search found in mainframe and PC ALEX. The source data for WebAJB is an output of the batch process run on the mainframe MVS system. The data is compiled nightly, transferred to the AIX system over an HCON terminal session, and then an automated FTP process is used to move the files over the Internet from the AIX system to NYSERNet where the WebAJB system is hosted and maintained. The replication of the self directed search is accessed via Common Gateway Interface⁷ programs on the BSD/OS using Perl scripts and custom C programs. Over 90% of the system is written in C. The initial porting implementation of WebAJB was just over 40,000 lines of code. This version was identified as Version 1.0.
- 3) After the initial success of the WebAJB system, America's Job Bank offered states an opportunity to implement a state version of the WebAJB system. The requirement for the state was to produce local data in the format required by the WebAJB system.

Currently, 19 states run state WebAJB based systems using Version 1.1. These systems are all hosted at NYSERNet where the hardware, system software and application code are maintained. Similar to the primary WebAJB system, these servers run on Intel Pentium systems under the BSD/OS operating system and the application code is the WebAJB base with minor modifi-

cations for each state.

- 4) An important enhancement to the WebAJB system was to enable employers to directly input job openings via the World Wide Web. Authorization procedures were coded for employers to request access for job input capability. In addition, verification procedures were constructed to allow AJB staff to review jobs submitted by approved employers before posting them to the WebAJB system.

This enhancement was implemented in a manner different from the base code. Information used to manage the approval and verification process as well as the actual job openings submitted by employers are stored in a relational database and programs running on the Web server access the RDBMS running on another system. This can be represented as follows:

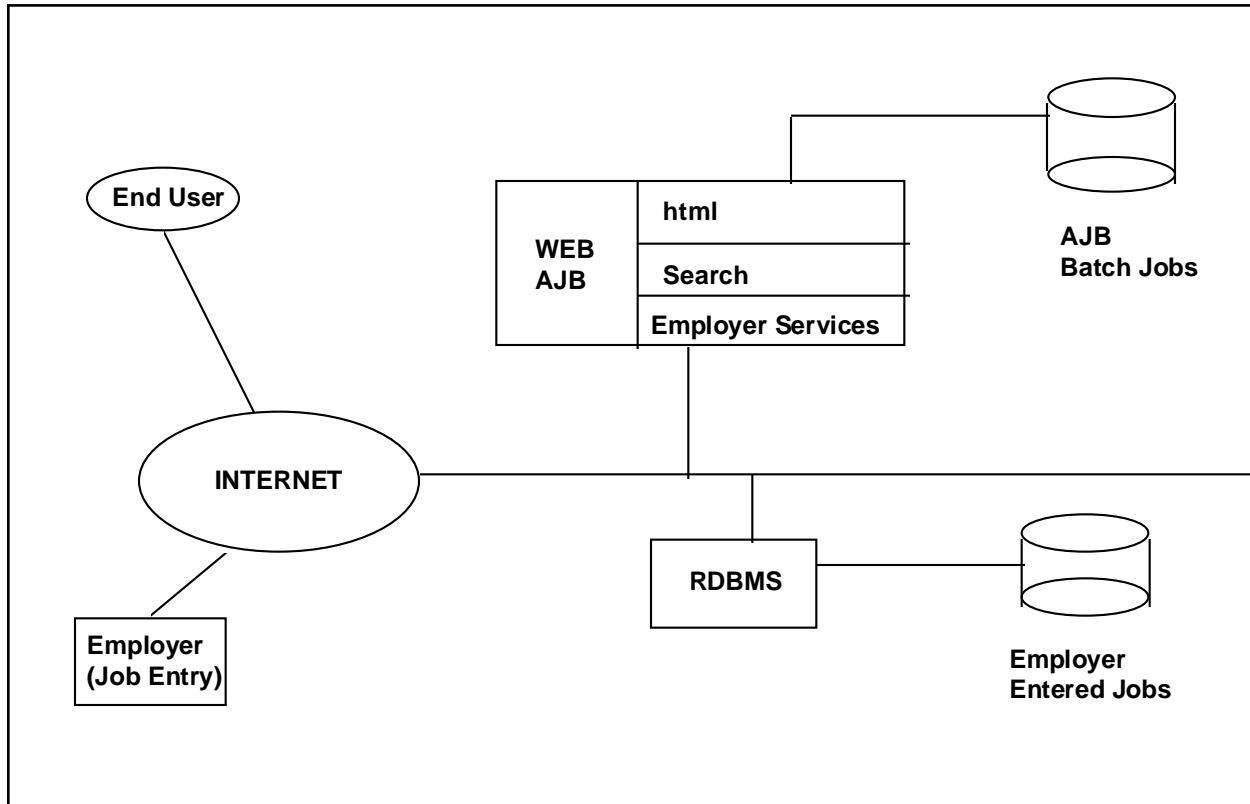

All programming to implement the employer services components (authorization, verification, and job order maintenance) are written in C and access an Oracle 7.1.4 database running under Sun OS 4.1.4 on a Sun Sparc 20. The addition of these features constituted Version 1.1.

- 5) Another set of programs developed using this configuration established a new search. The new search prototype is a replacement for the self directed search in the Version 1.X system. Prototyped using flat files and RDBMS⁸ files, the new search provides a new hierarchical structure for search selection, job counting during the selection process, as well as key word search capability.

The development of the new search marked the starting point of the re-engineering of the application architecture. It started the move to a new platform (DEC Alpha/OSF), featuring a redesigned data structure. The revised and rewritten system is identified as Version 2.1 and consists of just over 20,000 lines of code.

Usage of America's Job Bank on the Web

The impetus for future development of America's Job Bank on the Internet is driven by its success to date, as evidenced by the following table.

April, 1996 Statistics (valid through Friday Apr 26, 1996)

Total Server Accesses	30,671,993
Accesses Last 7 Days	1,296,540
Accesses Previous 7 Days	1,277,739
Total For Yesterday	199,447

Over 102,889 gigabytes transferred to date.

Future Strategy

Up to Version 2.1, AJB on the Internet has been largely a stand-alone application, even though it receives coordinated input from existing systems.

The AJB strategic plan attempts to chart a direction addressing the near to mid-term in specific terms, while providing an important strategic direction for the long term. The plan represents fundamental changes in the way AJB currently provides services. A fundamental challenge addressed is the recognition that current systems, practices, and procedures must be maintained while the future plan is developed and implemented.

Assumptions

- 1) End user Internet access with enhanced searching tools is critical for long term success.
- 2) Feature additions such as direct employer job entry must be expanded to compete in the evolving global Internet marketplace for job services.
- 3) There is a national trend toward providing state level online job services over the Internet.
- 4) Internet connectivity and protocols are viable solutions for data collection and distribution.
- 5) States will continue to run state level systems - some of which may not be based on Internet strategies.
- 6) The national system must provide flexibility for state participation while providing benefits to those electing to participate.
- 7) Existing systems, procedures, and practices must be maintained while new systems are being developed.

Design Objectives

Given the assumptions stated above, the following design criteria are being used to shape the strategy:

- 1) Open architecture strategy
 - ◆ Built on common, open protocols and standards.
 - ◆ Support for integration of multiple platforms and operating systems.

- ◆ Supports options for state level participation and integration and coordination of state systems.
- 2) Flexibility at application level
 - ◆ Coordinated alternatives for state participation with migration options.
 - ◆ Rapid code development and management environment.
 - 3) Scalable
 - ◆ Cost effective, efficient resource use with growth options and portability.
 - 4) Strategic
 - ◆ Establishes a direction upon which a migration plan can be built to move from current systems. Must define a strategic direction upon which future systems can be planned and implemented at the national and state levels.

The Strategic Plan

The goals and objectives of the strategic plan can be summarized as follows:

- 1) Create a new application architecture to establish a new national system providing state level flexibility while maintaining national coordination. Specific objectives related to this new architecture are to change the fundamental structure (architecture) of how the system is built and to enhance and expand what the application does.

Change the architecture:

- a) Transition to RDBMS⁹ foundation.
- b) Develop alternatives for state level participation, while maintaining current offerings.

Enhance and expand the application:

- a) Enhance and expand end user search and other applications.
- b) Enhance and expand direct employer services.
- c) Develop new components including NJIS and LMI¹⁰ data systems, career and training evaluation, and talent bank/resume options.

- 2) Transition to the Internet as the network infrastructure to support all aspects of the system.
 - a) End user access to new AJB system.
 - b) Direct employer job entry via the Internet.
 - c) Collection and distribution of data to/from state systems.
- 3) Migrate batch processing to a mid-range platform, eliminating unused processes and reengineering remaining needs within the framework of the new application architecture.

Application Architecture

This plan proposes to move from the current mainframe based implementation to a mid-range based system using a relational database management system to support enhanced end user functionality and new mechanisms and alternatives for state participation.

Required Changes:

- 1) Move away from the current mainframe batch source of data to a new data and application architecture. This new architecture uses clearly defined table based data to drive all components of the system including integration of state level system.
- 2) Replace state format conversion utilities currently on the mainframe with alternative processes that give states options for submission of data from existing and future systems over the Internet. These conversion utilities and integration tools are proposed to be implemented on server based systems acting as distributed server agents for the national system. Alternatives will be explored for implementing these server agents both centrally and remotely.

Together these changes establish a new processing paradigm and flow for America's Job Bank by taking conversion out of the batch process and putting it in the control of participating states, giving them increased options using tools supplied by the new application and underlying architecture.

This new architecture can be represented as:

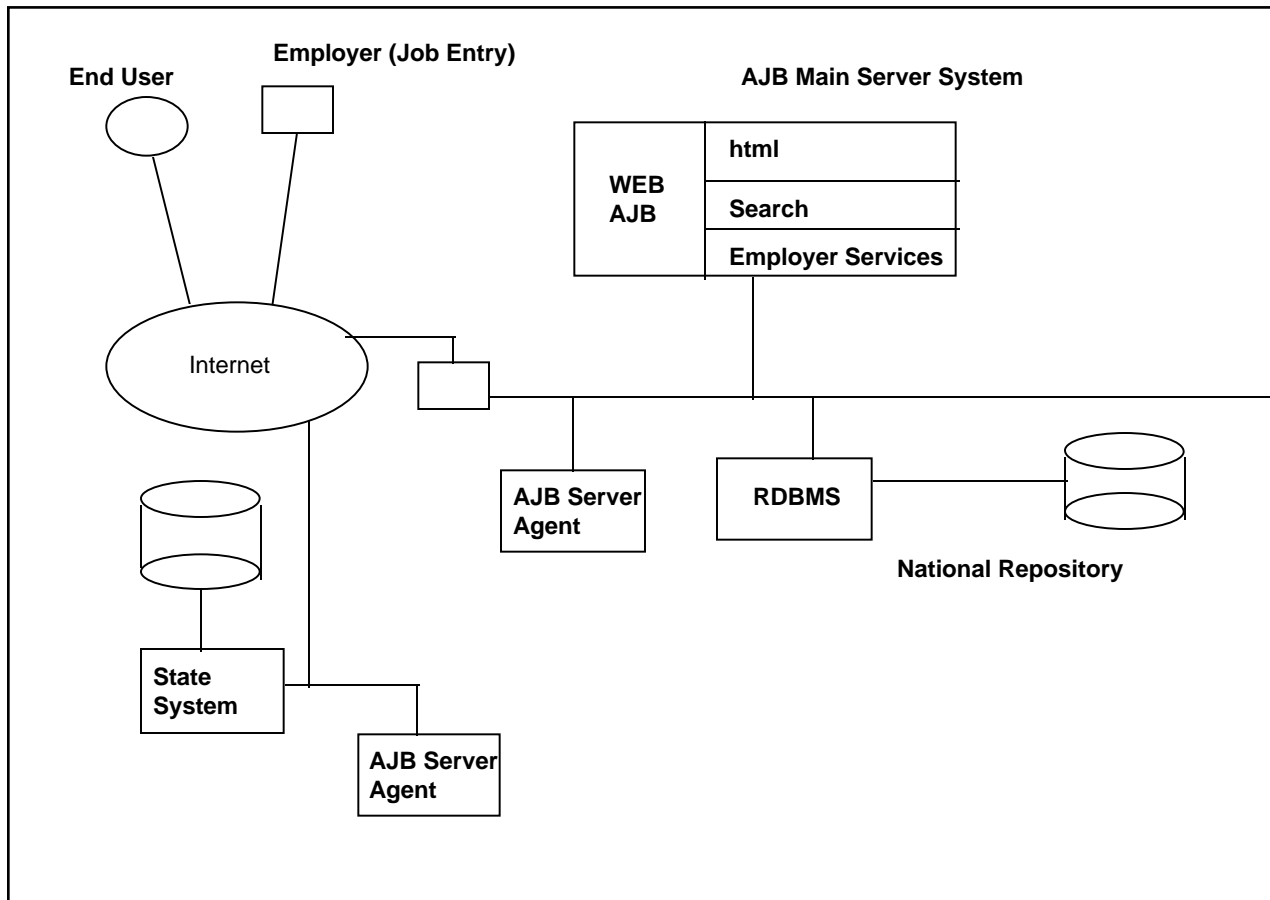

In the current system, states submit data in local format and conversion is performed on the mainframe. The proposed approach is to move the conversion function as close to the state level as possible. It is necessary, however, to do this in a way that advantages the state and makes it easy for them to participate.

The proposed server agent structure moves in this direction. The server agent functions as a mapping and conversion utility that is located between the state level system and the national repository. The essential design of the server agent can be viewed as being very similar to many Electronic Data Interchange (EDI) packages that provide forms or template driven interfaces to map and convert data from proprietary systems to a standardized common format.

Beyond this conversion facility, the server agents provide additional functionality to manage state file submission to, and national compilation retrieval from, the national repository. This additional functionality can be extended to current batch processes such as referral tracking as well. Access to the server agents is provided through authenticated logons. States can run a server agent locally or connect remotely with a Web browser to a centralized server agent.

The server agents are implemented on the Web platform for maximum interoperability and portability. Interoperability is achieved by basing all functions performed by the server agent on existing standards and protocols. For example, file transfer from the server agent to the national repository is handled using the FTP¹¹ protocol. End user administrative interfaces on the server will be constructed using the HTML 3.0¹² standard specification. Programs to handle data mapping, conversion, and tracking submissions to, and retrieval from, the national repository will be implemented according to the CGI Version 1.1 specification and written in C.

In addition to providing the server agent functionality described above, this approach has the significant advantage of allowing interested states to benefit from the development of the WebAJB system itself. States electing to use distributed server agents (servers located at the state) can also be provided functioning end user search and employer entry systems.

Network Based Data Collection And Distribution

This plan proposes moving to the Internet as the network infrastructure for all aspects of the AJB system. The objective is to have all transmission to and from the AJB system happen over the Internet after some transition period.

To affect this transition, a process was developed to accept main-frame bound files over the Internet, effectively eliminating the need for the RJE/NJE network for states with Internet connections.

Internet support for files sent to the MVS system is provided as follows without requiring TCP/IP on the MVS system:

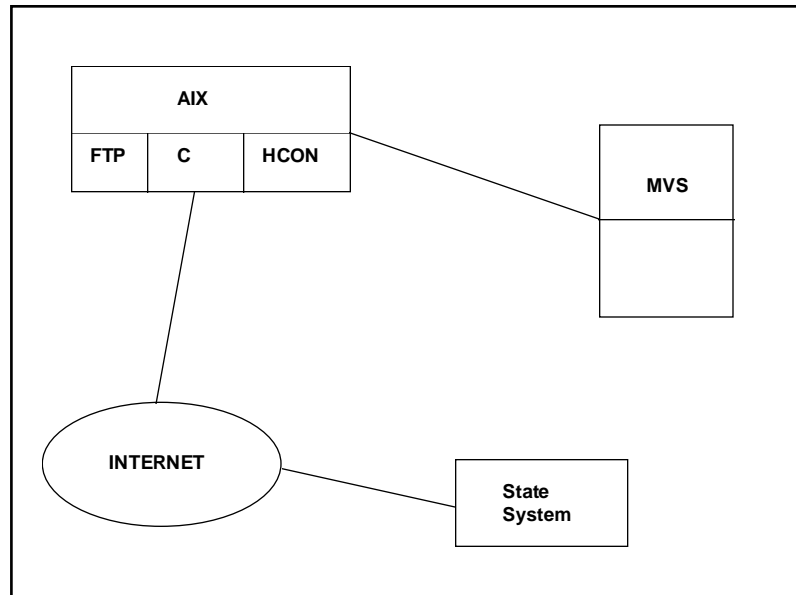

There are many alternatives to this implementation, including putting TCP/IP or some subset of that protocol stack on the MVS system to provide direct support for FTP. This would require additional software on the MVS and other associated systems.

¹ CICS is an online transaction protocol used in IBM mainframe systems.

² RJE (Remote Job Entry) and NJE (Network Job Entry) are protocols used to run batch jobs on an IBM mainframe.

³ AIX (Advanced Interactive Executive) is IBM's version of the UNIX operating system.

⁴ SNA (Systems Network Architecture) is a networking architecture and protocol commonly used by IBM.

⁵ MVS (Multiple Virtual Storage) is a common operating system found on IBM mainframes.

⁶ HCON allows the workstation to simulate a 3270 terminal session with the mainframe. The 3270 is a "dumb" terminal which can send keystrokes to the mainframe and receive information back from the mainframe via screen output.

⁷ The Common Gateway Interface standard is commonly used to communicate between the Web server program and other back-end applications, such as database implementations.

⁸ Relational Database Management System

⁹ Relational Database Management System

¹⁰ Local Management Interface

¹¹ FTP (File Transfer Protocol) is the standard protocol for transferring files over the Internet.

¹² HTML (Hypertext Markup Language) is the standard language for creating Web pages.

Case Study of SUNY System Administration's Purchasing Card System: A Prototype for Connecting the Web to a Legacy System

© 1996 Deloitte & Touche Consulting Group/DRT Systems. All rights reserved.

Abstract

Deloitte & Touche Consulting Group/DRT Systems (D&TCG/DRT), in cooperation with: New York State Center for Technology in Government (CTG), and State University of New York (SUNY), evaluated four (4) middleware products designed to support the development of WWW applications. The mainframe legacy system selected by CTG and SUNY for purposes of this evaluation was the SUNY System Administration Purchasing System and Card Procurement System. The legacy subsystem chosen for our evaluation processes Card Procurement transactions, and is a component of the larger SUNY System Administration Purchasing system. This application is used to log credit card transactions and allows SUNY departmental card holders to perform reconciliations of statements.

The middleware products evaluated in the case study were also selected by CTG and SUNY, and are listed below:

- ◆ WebDBC
- ◆ Oracle WebServer, Version 1.0
- ◆ Cold Fusion, Version 1.0
- ◆ Bluestone Sapphire, Version 2.0

Please note there are numerous other similar middleware products available in the market place.

The specific objective of this case study is to provide information regarding the relative effectiveness of the subject middleware tools, through their practical application, in supporting the processing of transactions through the use of a Web Browser connected to a Web server. The Web server is connected to a mainframe CICS online transaction system; the connection is established via either a direct CICS - VSAM cluster connection, or through the use of an ODBC (Open Database Connectivity) connection to CA/DataCom.

This case study contains supporting material for the presentation given by D&TCG/DRT at the World Wide Web as a Universal Interface to New York State Government Services program, sponsored by

CTG. Throughout the rest of this case study, you will find information related to the evaluation process in the following areas:

- ◆ architectural design issues encountered
- ◆ other peripheral software products used
- ◆ details of the middleware software evaluations
- ◆ an evaluation matrix for middleware software compatibility and feature comparisons
- ◆ implementation considerations when setting up a Web-to-legacy system architecture

Every effort has been made to present evaluation findings in an objective, fair, and accurate manner.

Why Consider Integrating Mainframe Legacy Systems with the Internet/WWW?

Many truly useful business applications - systems that involve the processing and presentation of critical and strategic information - still reside on the mainframe computing platform. The concept of connecting mainframe legacy systems to Web pages seems to make sense in that it may allow organizations to significantly improve the efficiency with which services and information can be delivered to customers and constituents.

In a public sector context, consider the mainframe-based entitlement applications still in operation today at government agencies, processing tens of thousands of transactions per day. They may not be much to look at, but these time-tested, often-extensively-modified mainframe legacy systems get the job done quickly and correctly.

Information systems executives, faced with the challenge of maintaining, modernizing, and optimizing their applications portfolios, should not ignore the potential advantages that a Web-to-legacy system solution may provide. In addition to preserving the huge capital investments typically made in the acquisition and maintenance of legacy systems, the inclusion of a mainframe application component in an enterprise computing architecture may be a preferable technical design alternative, especially given the complexities often associated with application redesign and redevelopment efforts - business requirements (re)definition and reengineering, development costs, hardware and software costs, software customization, retraining, user time constraints, long delivery cycles, and so on.

Forward-thinking organizations may elect to explore the possibilities, and ponder some of the potential benefits specific to an Internet/WWW-legacy system solution.

Potential Benefits Affecting the Organization Internally

- ◆ World-wide, 24-hour, PC-based, real-time access to mainframe business applications, limited only by the availability of the legacy system itself and Internet services, may allow for anyplace / anytime transaction processing by application users and data entry staff.
- ◆ Graphical user interfaces (GUIs), tailorable to the specific processing needs and preferences of business application users, will supplement the character-based presentation and procedural orientation of legacy systems, resulting in reduced user training costs and improvements in application users' performance and overall satisfaction with the computer system.

Potential Benefits Affecting the Organization Externally

- ◆ Linking people with service providers offers dramatic improvements in customer/citizen access to information and services. Using our mainframe-based entitlement applications example, there may be opportunities to consolidate these systems within the design of a single Web page (one-stop shopping at the Virtual Entitlement Mall), allowing for the interaction of qualified citizenry with the departments of Social Security, Medicare, and so on, from that one Web page. Citizens using multiple public services, particularly the elderly, immobile, or isolated, could benefit greatly.
- ◆ Again in the public service context, linking government agencies with other government agencies, and with private sector service providers, may offer important advantages. With Congress transferring new responsibilities to state and local government agencies, innovative ways of handling these new programs may need to be devised. Intragovernmental collaboration and privatization initiatives will likely be considered in the strategic deliberations of the newly "authorized" state and local governments. Legacy systems available through the Internet/WWW may play a significant role in assembling cost effective, comprehensive solutions in response to these newly acquired "authorizations," all without the trouble and expense of constructing private networks.

Internet/WWW-Legacy System Technology: A Practical Prototype

The 1995-96 New York State Budget recommendations introduced a purchasing practice for New York State expected to reduce paperwork and expedite payment to vendors by utilizing a procurement card. Modeled after successful programs used in the Federal government and the states of California, Virginia, and Oregon, a select group of state agencies, including SUNY System Administration, agreed to pilot this system. American Express (AMEX) was awarded the contract to provide New York State with procurement card services.

The AMEX Corporate Purchasing Card enables cardholders to make authorized purchases directly from a vendor without processing the purchase orders or purchase authorizations currently required. Cardholders are able to make purchases of \$500 or less. Cardholders must reconcile their statements on a monthly basis.

The American Express Procurement Card (APEC) online system was developed by SUNY System Administration to handle the accounting and administration functions to the State University procurement card program. The system consists of a variety of transaction screens available for use by cardholders, department managers, accounts payable department and program administrators.

APEC is character based and resides on the mainframe at SUNY Central. Cardholders currently access the mainframe via proprietary channels: SUNYNet, the university's campus network, and IBM's CICS online transaction system. SUNYNet is currently available on all 64 of the SUNY campuses. However, it is primarily available in campus business offices. University employees in academic departments and other campus departments typically do not have access to SUNYNet.

Current Access to APEC

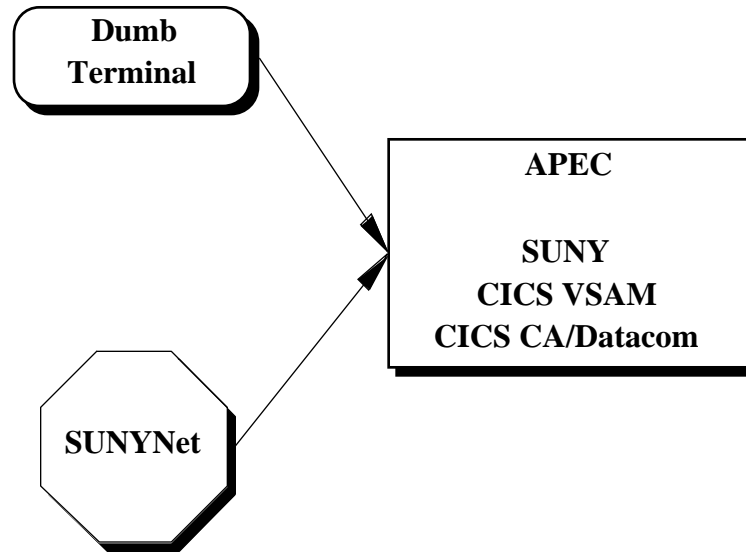

The Prototype

The goal of the project was to develop a prototype to support access to the SUNY legacy procurement database from the graphical user environment of the World Wide Web. Direct access to the legacy database from the Web would allow employees to access the procurement card system from any location, not just those locations with access to the proprietary systems, to enter transactions and reconcile their accounts, to review account balances, and to review which bills have been paid. The reconciliation process could take place on the road, in the office, or at home using the same GUI interface.

In considering a prototype Internet/WWW-legacy system implementation, SUNY Administration officials cited the following two (2) business objectives:

- ◆ Provide authorized business application users with wider access to the procurement card system
- ◆ Renovate the existing character-based screens; provide a friendly and effective presentation of the application through the development of a graphical user interface

SUNY System Administration worked with CTG and the project partner, Deloitte & Touche Consulting Group/DRT Systems to develop a prototype application that would create an interface to the procurement card system from the World Wide Web.

The prototype design was kept as simple and readable as possible. In order to accomplish this task several conventions were used in the Web page design.

Simple design. The overall design was for one page of displayed data. This eliminated confusion and reduced the chance of an end user moving between pages which could lead to inconsistent display data.

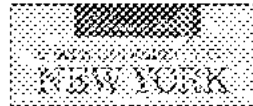
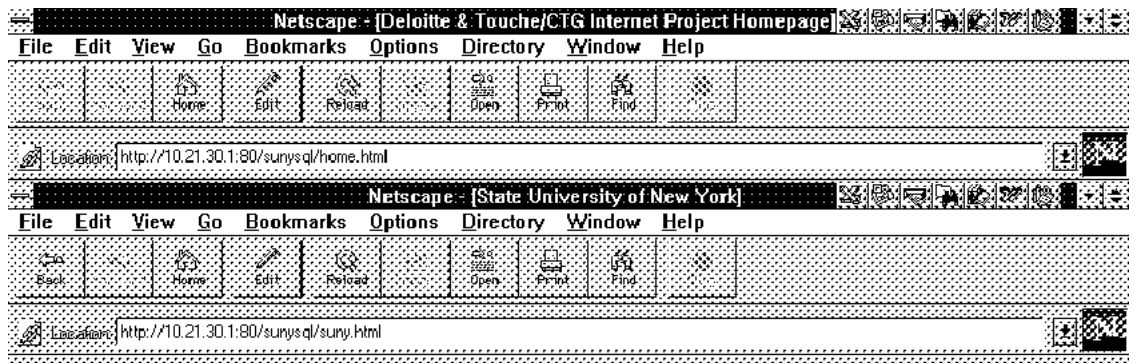

State University of New York

Campus Code :	<input type="text" value="28650"/>
User ID :	<input type="text" value="rarg"/>
Password :	<input type="text"/> <input type="button" value="Security Pass"/>
Job Function :	<input type="text"/> <input type="button" value="Clear"/>

- ◆ **Bookmarking.** Each section of the page (general information, detailed account information and verification) was bookmarked and separated so that the user can easily navigate from section to section without the use of scroll bars.

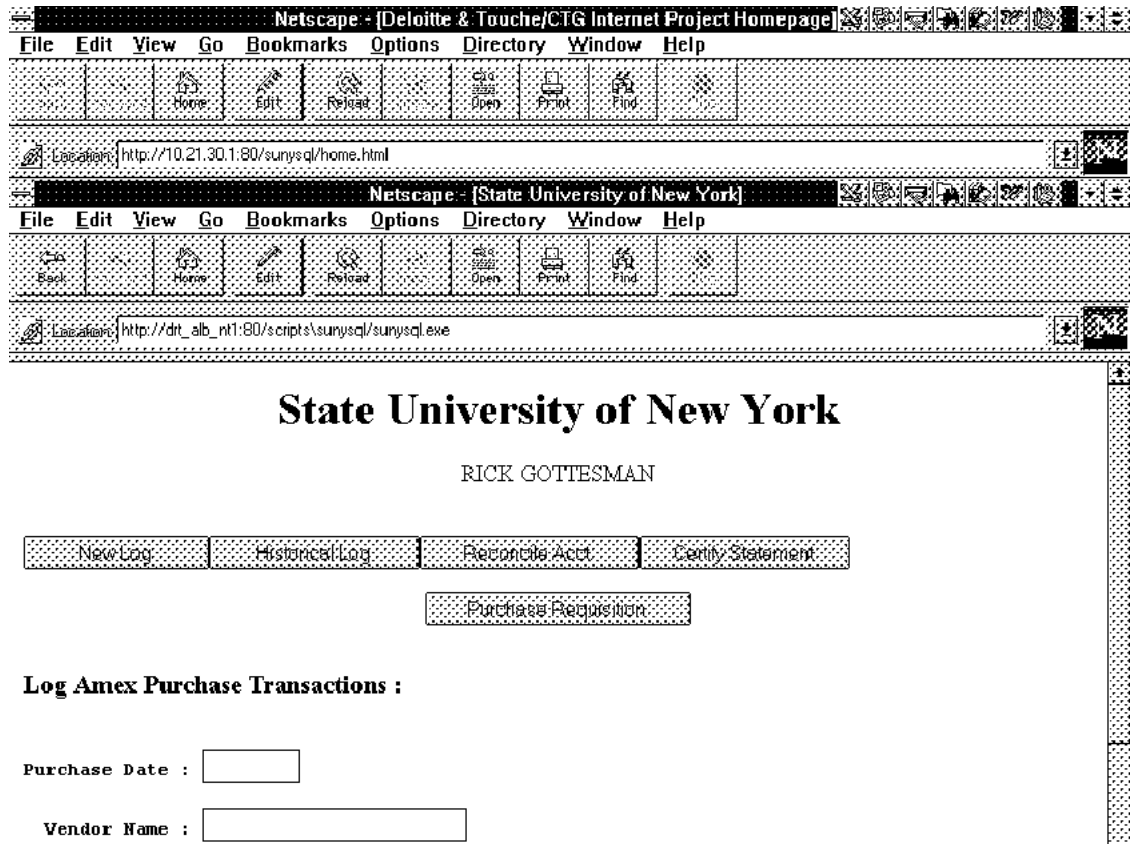

- ◆ **Navigation Icons.** Each of the above mentioned sections has a small help icon that leads the user to a help page for that section. This help page clearly and concisely explains what each of the fields mean.
- ◆ **Visual Cues.** Important fields are emphasized by color or bold print so the user can quickly pick out information that is commonly used.

- ◆ **Drop Down Lists.** Where appropriate drop down lists are used to provide information about codes supplied by the mainframe. For example, a card status of 'A' means active and 'V' means void. Experienced users will know this and will not take the time to use the drop down list, however novice users may need the extra information to accurately interpret the form.
- ◆ **Limited Choices.** The Web page will be a dead end and will not have any links to other pages (save the help pages). The only action the user can take is to return to the login or information input screen.
- ◆ **Lowest Common Denominator.** The page will only contain graphics that are needed to make the data readable. Logos and large banner bit mapped images will be discouraged so that users on low end machines can quickly receive and view the page.

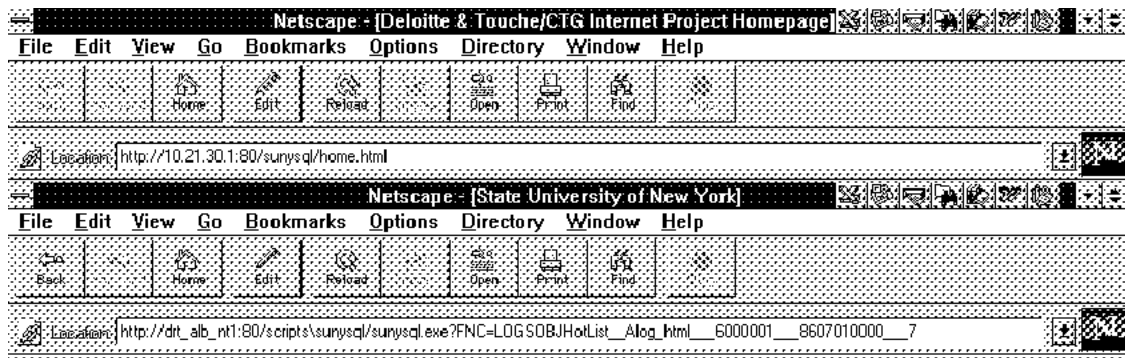

State University of New York

RICK GOTTESMAN

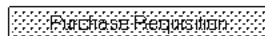

Amex Purchase Transaction Log Detail :

SOBJ	Fiscal Yr.	Amount	Charge Agency	Req. Type	Req. P0 Number	Req./P0 Line No.	Log No.	Line No.
3095	95	152.4	28650	R		0		

The Internet/WWW-legacy system prototype developed for this evaluation accomplishes the desired objectives:

- ◆ Authorized business users can create, modify, and reconcile procurement card data residing on the mainframe on an anytime/anywhere basis, provided there is an Internet connection available
- ◆ Real-time, state-wide access to procurement card data is available throughout the SUNY network, accommodating the geographically distributed nature of procurement card processing
- ◆ A graphical user interface for the application is in place
- ◆ Users of a SUNY-issued card can access the Web application, visit the Web site, and review their own transaction data.

The following figure represents the layout of the prototype and some of the implementation options.

CTG Web to Legacy Project - System Layout

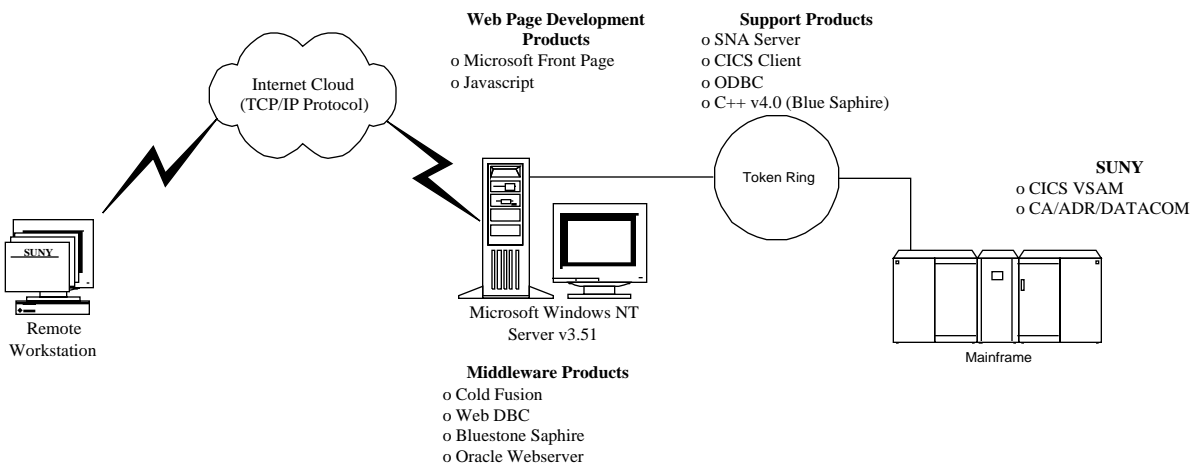

Internet/WWW-Legacy System Technology: Tactical Considerations

The opportunities for exploiting the integration of Internet/WWW and mainframe legacy system technologies seems quite promising. It is suggested that organizations take a measured approach to creating Web-to-legacy system applications, and that the following recommendations be given due consideration:

Start small. An organization's initial attempt to leverage this technology should first take into consideration some key parameters, such as: (1) the identification of manageable, relevant business processes that could benefit from such an approach. The opportunities for exploiting the integration of Internet/WWW and mainframe legacy system technologies seems quite promising. It is suggested that organizations take a measured approach to creating Web-to-legacy system applications, and that the following recommendations be given due consideration, and satisfy an important business objective; (2) the appropriate scoping for a prototype / proof-of-concept project, ideally a relatively low-risk, scaleable, inquiry-only application.

Assess your business risks carefully. A hasty inclination to take advantage of the Internet/WWW-to-legacy system integration technologies should be tempered with an awareness that the middleware enabling such connectivity may not yet be mature technology and, as such, may be prone to technical imperfections. Accordingly, a benefit-risk analysis is advisable, based on either qualitative measures or quantitative probability modeling, taking into account potential customers/constituents, revenues, and investment costs.

Make an informed decision. Spend the time and make the effort to educate staff in the appropriate technology areas, and/or hire specialized consultants to accelerate the learning process and act in an advisory capacity.

Assess security implications. This is an area that should be carefully examined before proceeding. For more information on Internet/WWW security issues, you may wish to examine CTG's Web page on Internet Security located at <http://www.ctg.albany.edu/projects/inettb/security.html>.

Internet/WWW-Legacy System Technology: Development Resource Considerations

~~This evaluation/case study provides an experience base from which to make informed suggestions regarding the types of resources and skill sets that would be required for a similar small-scale implementation.~~

Application developers working on Web-to-legacy system integration projects need to have a good understanding of, and experience with, web page development techniques and possess an understanding of GUI design and development. The development team may also need support in 3GL and 4GL programming areas, such as C++ or Visual Basic, in order to develop application components designed to send and receive information from the mainframe system. Some of the products evaluated required the development of C++ routines to facilitate user ID authentications, as a supplement to the core functionality provided by the middleware product. Development of a Web interface may also require developers to write SQL statements to support database I/O.

Organizations considering such an implementation, but lacking the skills base to assemble an effective internal implementation team, may benefit greatly from contracting development and mentoring services from an experienced Internet/WWW development services vendor.

Evaluation of Middleware Products: Approach

The four middleware products evaluated as part of this case study were selected by CTG and SUNY for the purpose of demonstrating the technical ability to construct a Web-to-legacy system application. D&TCG/DRT has performed an impartial study of the four middleware products and, as such:

- ◆ our findings are relative comparisons limited to the product evaluation pool
- ◆ D&TCG/DRT makes no claim at this time that any of the four middleware products represent best-of-breed products

Each middleware product was evaluated using the following criteria:

- ◆ Ease of use with respect to installation, development environment, and scripting language
- ◆ GUI generation capabilities
- ◆ Connectivity
- ◆ Security
- ◆ Speed

Middleware Evaluation

Internet Address: www.allaire.com

Cold Fusion Version 1.0

Cold Fusion is a Web Application Development(WAD) platform for Windows NT and Windows 95. It enables you to create a variety of applications that integrate with relational databases.

Overall impression

Very good product. We installed the software on Microsoft Windows NT 3.51 server (Intel-based). The software setup was simple and very easy to install. The functionality proved to be exceptional and easy to maintain, providing several choices for connecting to different data sources. Also provided a quick way to develop a Web page although it did not provide a robust interface to create the page.

Installation

- ◆ Requires some knowledge of web servers (i.e. Common Gateway Interface (CGI) paths).
- ◆ It is possible to configure server incorrectly if you are not using a well-known web server.
- ◆ The Open Database Connectivity (ODBC) data sources must be System DSN.
- ◆ The Cold Fusion Administration provides an ODBC verification.
- ◆ Cold Fusion runs as a Service on Microsoft Windows NT v.3.51.

ODBC Support Services

- ◆ Cold Fusion will enable a connection to a wide variety of ODBC compliant data sources. It can also verify the ODBC connection before you begin working with the tools.
- ◆ Cold Fusion has no known native connections to any relational database management system (RDBMS).

Other Connectivity

- ◆ The ODBC facilities are the only source of connectivity.
- ◆ It does not provide any Application Programming Interface (API) support.

Development Environment

- ◆ The product does not offer any GUI authoring tools. You must develop the Web page using a third party product such as Microsoft FrontPage. However, in the current version the TAGs do not consistently translate well. Future releases will address this

issue.

- ◆ Provides robust database functionality.
- ◆ The language supports IF ELSE, variables, forms and HTML tables.
- ◆ The ability to customize views of Web pages is not as robust as some of the other tools.
- ◆ Allows for the call of stored procedures (with parameters) in databases that support them, such as Microsoft SQL Server.
- ◆ Cold Fusion uses templates instead of HTML documents. A template is a standard text file that contains both the HTML and Cold Fusion's DBML(Database Markup Language).

Scripting Language

- ◆ Easy to use, even for the novice developer. It provides a straight forward interface, as well as a good debugging output facility.
- ◆ Does not require coding in a traditional programming language such as Delphi, C/C++, Visual Basic, or Java.
- ◆ Cold Fusion applications can be developed quickly because of its template objects and how well they integrate with Web sites.

Speed

Provides acceptable speed for queries and allows the user to set limits on the time for a query and the max-rows retrieved. Both are parameters which can be passed.

Conclusion

With Cold Fusion, you can leverage the power of the Web and relational databases to create dynamic Web sites or full blown Web applications.

Internet Address: www.Oracle.com

Oracle WebServer Version 1.0

The evaluation of this product reflects the merits of the most current product release available at the time this evaluation was conducted. Due to the time constraints of this study, we were not able to conduct an evaluation of the recently-released Oracle WebServer 2.0.

Overall impression

- ◆ This product is robust and the best choice if your platform is Oracle-based. However, it does not support integrating with other database environments. WebServer has many features for connecting to a database system.

- ◆ We would not recommend using as a traditional Web Server.
- ◆ WebServer provides support for a wide range of platforms (WebServer 2.0 supports over 12 different platforms).

Installation

- ◆ This installation is somewhat complicated, requiring knowledge of web servers and Oracle in general.
- ◆ The installation uses a GUI for the setup process.
- ◆ The WebServer 2.0 setup and installation facility is reportedly significantly easier to use.

ODBC Support Services

- ◆ The product supports ODBC connections to other databases.
- ◆ The documentation does not outline in detail how the connections are established.
- ◆ Our evaluation revealed that most of the functionality is diminished when used against a non-Oracle database.

Development Environment

- ◆ WebServer does not offer GUI authoring tools, but will work well with third party authoring tools such as Microsoft FrontPage.
- ◆ Environment uses custom TAGS to retrieve information from the database.
- ◆ Provides a full repertoire of programming functionality through PL/SQL, if you are using Oracle.
- ◆ Stored procedures for the database queries must be set up on the Oracle side.

Scripting Language

- ◆ Scripting language is both functional and flexible, providing all the necessary tools to develop complex queries.
- ◆ In order to take full advantage of this product, you must have a good knowledge of Oracle and PL/SQL.
- ◆ Scripting language is mature and provides a solid foundation for SQL services.

Speed

- ◆ This version tends to be slower than a traditional web server, but provides better memory management services.
- ◆ Has better management of the background processes via the Web-broker.
- ◆ Supports caching of files and provides memory mapped files.
- ◆ Oracle WebServer version 2.0 is reported to be a faster product

than Version 1.0.

Conclusion

This product is the best choice if you are working within the Oracle environment, and have a good understanding of PL/SQL. We do not recommend this product for the novice developer.

Internet Address: www.ndev.com

WebDBC Version 2.5

Overall Impression

- ◆ Very well rounded product with versions for a variety of platforms.
- ◆ Supports most popular Web functions (e.g. forms and buttons)
- ◆ Provides excellent connectivity and a good programming language interface.
- ◆ Product is the best for applications processing multiple ODBC databases and requiring more than simple displaying of results from a select statement.
- ◆ Supports multiple platforms such as Windows NT (as a service), Windows NT, MacOS and Unix.

Installation

- ◆ The user must have some knowledge of Web environments.
- ◆ Setup uses GUI tools but supports the administration tasks through the use of HTML pages.

ODBC Support Services

- ◆ Product will only support the 32-bit environment, therefore 16-bit PC operating systems can not take advantage of this product through ODBC.
- ◆ For 32-bit operating systems, this product supports a wide range of drivers.

Development Environment

- ◆ WebDBC does not support any internal GUI authoring tools, therefore you might want to use a third party tool such as Microsoft FrontPage.
- ◆ WebDBC uses special TAGS to connect to the database
- ◆ Product uses HTX files to gather the user queries and responses dynamically.
- ◆ Product supports the use of DLLs, CGI, and API functions.
- ◆ The language also supports flow control statements (such as

“If,Else,If” and “And/Or”) and variable declarations. The programming language can be cryptic, however we found it to have a minimum learning curve to develop basic scripts.

Scripting Language

- ◆ Most 3GL functionality is supported through its scripting language.
- ◆ WebDBC provides support for most Web Browsers.
- ◆ Product evaluated on Netscape Browser 3.0 and Microsoft Internet Information Server Scripting language allows you to gather information about the servers and clients using WebDBC.
- ◆ WebDBC functionality for debugging is basic.
- ◆ All SQL commands are supported in this version.
- ◆ Product WebDBC also supports stored procedures, SQL strings, deletes, inserts, and updates to create read or writable services.

Conclusion

This product was found to be well-rounded and suitable for most platforms. The connectivity was above average and the development tools were easy to work with. Best product for multiple ODBC databases that require more than simply displaying of the results of a select statement.

Internet Address: www.Bluestone.com

Bluestone Sapphire

Overall impression

- ◆ Product is very powerful and offers a great deal of functions to a developer.
- ◆ Product is very flexible and extensible.
- ◆ Provides a true client/server environment, and is designed for creating new applications as well as linking to existing applications on the Internet/WWW.
- ◆ Offers a visual development tool and an open architecture design for porting Web applications.

Installation

- ◆ Installation requires a general knowledge of web servers and browsers during setup.
- ◆ GUI-based installation facility is easy to use.

ODBC Support Services

- ◆ Product provides a simplified access to data sources using an ODBC approach, allowing the user to take advantage of a wide variety of SQL environments such as Informix, Oracle(PL/SQL), Microsoft SQL Server, SyBase, etc.
- ◆ Product was tested with Oracle and Microsoft SQL Server.
- ◆ Product supports a 32-bit ODBC environment, allowing easy access to a variety of ODBC data sources.

Other Connectivity

- ◆ Native connections can be established through the Sapphire gateway.
- ◆ ODBC, however, is the main avenue for connectivity.

Development Environment

- ◆ Sapphire supports for API, JavaScript, Microsoft VB Script.
- ◆ Product allows developers to take advantage of application and function objects, providing a way to utilize legacy objects for the Web.
- ◆ Product provides support for embedding OLE objects such as Microsoft ActiveX controls.
- ◆ Product has the capability to develop a rich graphical user interface, therefore there is no need to use a third party web page designer.
- ◆ The Sapphire development architecture, and its objects, are based on object creation and object binding.
- ◆ Product delivers built-in support for authoring wizards, browsers, and editors to facilitate the design of web pages within one development environment, while still maintaining tight integration with other web tools, such as Microsoft FrontPage. This is a significant advantage over the other middleware products evaluated.

Scripting Language

- ◆ Sapphire supports most scripting languages, including JavaScript and Microsoft VBScript.
- ◆ Some of the built-in tools available are JavaScript and VBScript data validation objects.
- ◆ Product generates CGI code in “C” or C++, allowing for the partitioning of applications across multiple platforms and operating systems.

Conclusion

We found this product to be most suitable for this proof of concept. It provides an OA to many different data sources and provides a robust developer interface. This product also provides common gateways. The connectivity was excellent and the developer tools were easy to work with. Best product for multiple ODBC databases that require more than simply displaying the results of a select statement. This is the product we selected to design our architecture for this case study and provide the gateway to the mainframe data for CICS and CA/Datacom. Best choice for this evaluation considering the components of the environment

Appendix A. Evaluation Matrix

Note: The evaluation matrix was completed by the vendors for each of the products. Information was not available on Oracle WebServer.

				Cold Fusion v1.0	WEBDBC v2.5	Sapphire/Web v2.0
Web Server						
	Apache				beta	x
	CERN				beta	x
	NCSA				beta	x
	Open Market			x	x(NT)	x
	O'Reilly WebServer			x	x	x
	Netscape			x	x	x
	HTTPD			x	x	x
	FastTrack & Enterprise			x	x	x
	Commerce & Communications			x	x	x
	Microsoft			x	x	x
	Internet Server			x	x	x
	IIS			x	x	x
	Process Purveyor			x	x	x
	EMWAC HTTPS			x	x	x
	Internet Factory System			x	x	x
	Spry Web Server			x	x	x
	CMS Alibaba			x	x	x
	Any CGI Compliant Server			x	x	x
	Any http, shttp ssl server				x	x
Web Browser						
	Netscape Navigator			x	x	x
	Microsoft Explorer			x	x	x
	HTML v2.0+			x	x	x
	VRML			x	x	x
	Java			x	x	x
	Active X			x	x	x

				Cold Fusion v1.0	WEBDBC v2.5	Sapphire/Web v2.0
Database Compatibility						
	Microsoft SQL Server			x	x	x
	Microsoft Access			x	x	x
		v1.0		x	x	x
		v2.0		x	x	x
		v7.0		x	x	x
	Microsoft Foxpro				x	x
		v2.0		x	x	x
		v2.5		x	x	x
		v2.6		x	x	x
	Oracle				x	x
		v7.0		x	x	x
	Borland Paradox				x	x
		3.x		x	x	x
		4.x		x	x	x
	Borland Dbase III and Dbase IV			x	x	x
	Microsoft Excel				x	x
		v3.0			x	x
		v4.0		x	x	x
		v5.0		x	x	x
	Watcom SQL 4.0			x	x	x
	SyBase			x	x	x
	Plain Text Files			x	x	x
	Informix			x	x	x
	ODBC			x	x	x
Operating System Platforms						
	Windows NT			x	x	x
	Windows 95			x	x	x
	SUN				beta	x
	SGI					x
	IBM RS/6000					x
	HP Series 9000					x
	DEC Alpha					x
		Windows NT			x	x
		UNIX				x

				Cold Fusion v1.0	WEBDBC v2.5	Sapphire/Web v2.0
Security						
	Database			x	x	x
	Table			v2.0	x	x
	Operation			x	x	x
	Authentication				x	x
		Database		x	x	x
		Operating System		x	x	x
	Privileges					
		1 level				
		2 levels				
		3 levels		x	x	x
HTML Editor						
	Microsoft Front Page			x	x	x
	Netscape Navigator Gold			x	x	x
	Hot Dog			x	x	x
	Hot Metal			x	x	x
	Notepad			x	x	x
	VI			x	x	x
	EMACS			x	x	x
	HTML v2.0+			x	x	x
ODBC Driver Requirements						
	Must be a 32 bit driver			x	x	x
	Comply with level 1 of the ODBC API			x	x	x
	Support Core SQL grammer			x	x	x
	Support Day/time data types			x	x	x

				Cold Fusion v1.0	WEBDBC v2.5	Sapphire/Web v2.0
System Requirements (minimum)						
	CPU			386	486/66	486/33
	Hard Drive Space			4 Meg	5 Meg	4Meg
	Memory			16 Meg	16 meg	16 Meg
	Protocols				tcp/ip	tcp/ip
DLL Interfaces						
	ISAPI			v2.0	x	v3.0
	NSAPI			v2.0	x	v3.0
	Apache				beta	
	WBGI (Spry)				x	
	WSACI			v2.0		
Gui Features						
	Radio Buttons			x		x
	Pull Down List Boxes			x		x
	Check Boxes			x		
	Icon Driven Menus			x		
				x		
Additional Features						
	Personal addition					x
	Enterprise addition					x
	Native Library Support					x
	Oracle					x
	Sybase					x
	Intermix					x
	MS-SQL Server			x		x
	ODBC					x
	Function support for CICS					x
	Executable Support			v2.0		x
	Java and Active X Framework					x
	File Upload and Download			v2.0		
	SMTP Support			x		
	Mime Attachment			v2.0		
	130 New Mathematical Functions			v2.0		
	Boolean Support and/or operators			v2.0		
	Full Flow Control			v2.0		
	Looping Capabilities			v2.0		
	Integration with Crystal Reports			Bundled w/v2.0		

Legal Notice

The information contained in this document represents the current view of Deloitte & Touche Consulting Group/DRT Systems on the issues discussed as of the date of publication. Because the products evaluated can change due to market conditions, it should not be interpreted to be a commitment on the part of Deloitte & Touche Consulting Group/DRT Systems, and Deloitte & Touche Consulting Group/DRT Systems cannot guarantee the accuracy of any information presented after the date of publication.

This document is for informational purposes only. Deloitte & Touche Consulting Group/DRT Systems MAKES NO WARRANTIES, EXPRESS OR IMPLIED, IN THIS DOCUMENT.

Microsoft, Win32, and Windows are registered trademarks, and Windows NT is a trademark of Microsoft Corporation.

DEC is a trademark of Digital Equipment Corporation.

Intel and Pentium are registered trademarks of Intel Corporation.

Netscape is a trademark of Netscape Communications Corporation.

Sun is a registered trademark and SPARC is a trademark of Sun Microsystems, Inc.

UNIX is a registered trademark in the United States and other countries, licensed exclusively through X/Open Company, Ltd.

This report may be reproduced and distributed, providing no part it is omitted or altered. All trademarks in this report are the property of their respective companies.

Chapter 4. Group Collaboration

Overview

Enhanced group collaboration would seem to be a natural consequence of the World Wide Web. The ubiquitous access of the Internet and the common interface provided by the Web lend themselves to an easy exchange of ideas and the opportunity for joint decision making. This collaborative process can range from a completely informal flow of ideas to a highly structured and purposeful interchange. In addition, collaborative models can be categorized by time and location. Synchronous groupware enables people to work together at the same time (usually from different locations), using such tools as whiteboarding, application sharing, file transfer, interactive audio, interactive video, and chat (real-time conversations that are transferred in text and displayed on each of the participant's screens). Asynchronous groupware allows contributions to be made over time, at the convenience of the participants. Tools in this category can range from simple e-mail to specialized applications that encourage focused problem solving. The benefits that can be expected from increased use of Web collaboration tools include the following:

- ◆ **Greater Participation in the Decision-making Process.** As government and industry enterprises are “rethinking, reinventing, and recreating” themselves to work more efficiently and effectively, workgroup collaboration tools are looked on as products that can widen participation in the decision making process. These tools help people work together independent of time and/or place and allow people at all levels with various skills to contribute to decision making.
- ◆ **More Opportunity to Generate Ideas.** Web-based collaboration tools can be used to generate ideas over a longer span of time than would be possible using traditional face-to-face meetings. As Dr. John Rohrbaugh and Dr. Sandy Schuman of the University at Albany pointed out in a recent Government Technology article, “Part of the reason for improved brainstorming in computer conferencing is the additional time for good ideas to lead to even better ideas, perhaps entirely new ways of thinking about a problem or its solution.” Ideas and decisions made over the Web can be used to replace conventional meetings or can be used to generate ideas in preparation for such meetings.

- ◆ **Cost Savings.** A reduction in face-to-face meetings can result in considerable savings in both time and money. These savings include the accumulated travel time and expense of each participant as well as the effort expended in organizing and implementing the meetings and conferences. Face-to-face meetings can be reserved for those situations where physical proximity is a critical success factor.

The Groupware Market

According to Virtual Workgroups Magazine, July/August 1996, there are over 20 million groupware users today with growth expected to reach 100 million over the next four years. Many of these users will be looking to the Web as their choice for groupware implementations.

A number of major software vendors are vying for this market. Product offerings include extensions to existing products (such as LOTUS Notes, Microsoft Exchange, the Netscape browser, or Microsoft's Internet Explorer) as well as new software developed specifically for the Web (such as Digital's WebForum). Product features vary widely and new features and products are introduced every day.

Practical Results

The project prototypes and related case studies have highlighted the need for careful planning and execution of any group process aimed at delivering explicit results in a specified period of time. Many groupware products do not provide for group facilitation or group management but simply allow for enhanced electronic communication to take place. A well thought-out process for moving the discussion forward is imperative for successful results. Groupware products currently exhibit limited use of group dynamics and group psychology. They seem best suited for small groups of two or three people.

Prototypes were developed to explore the features of synchronous groupware. These include implementations of Microsoft's NetMeeting and Netscape's Cool Talk. In addition, Web-based scheduling was explored with an implementation of WebCalendar. Asynchronous groupware was reviewed within the Education segment of the Testbed.

Synchronous Groupware

What is it?

Groupware is a commonly used term that lacks a commonly accepted definition. In general, groupware is a set of hardware, software, services, and technologies designed to help groups of people engaged in a common task or goal. It can be used in special purpose decision rooms or to support groups working in different places at different times or at the same time.

Technically, groupware is a computer-based system that provides multi-user interface, communication and coordination within the group, shared information space and the support of a heterogenous, open environment which integrates existing single-user applications. Groupware is often categorized according to a time/location matrix using the distinction between same time (synchronous) and different times (asynchronous), and between same place (face-to-face) and different places (distributed).

This investigation focuses on Synchronous Groupware, used on the Web by groups of people working together at the same time but in different places.

How does it work?

Generally, Groupware comprises several functionalities that can work separately or work with each other to achieve collaborative computing. The common functions in Web-Based synchronous groupware are:

- ◆ **WhiteBoarding:** A term used to describe the placement of shared documents on an on-screen “shared notebook” or “whiteboard.” It allows a document or image to be viewed simultaneously by two or more participants. All participants can then view the document while making annotations on it using the drawing or text capabilities of the specific whiteboard program. Most of the shared whiteboard programs use different colors to indicate whose annotations are whose. Some software includes “snapshot” tools that enable you to capture entire windows or portions

of windows and place them on the whiteboard. You can also use familiar Windows operations (cut and paste) to put snapshots on the whiteboard. You work with familiar tools to mark up the electronic whiteboard much like you do with a traditional wall mounted board.

- ◆ **Application Sharing:** Application Sharing allows you to conference with someone who may not have the same application programs you have. One person launches the application and it runs simultaneously on all participants' desktops so that all participants can view the application screen simultaneously. All users can input information and control the application using the keyboard and the mouse. Files can be transferred easily and the results of your conference are available to all users immediately. This kind of application is designed to allow participants at multiple sites to view and sometimes control it. Usually, the person who launched the application can lock out other persons from making changes, so the locked-out person sees the application running but cannot control it.
- ◆ **File Transfer:** A method for transferring files from computers connected to the Internet. It helps people transfer files (text, images, binary etc.) they need to and from their colleagues' computers while they are in a meeting.
- ◆ **Chat:** A network chat program is a form of interactive online communication that allows you to have real-time conversations through your computer. When participating in a chat discussion, your messages are instantaneously relayed to other members in the chat room while other members' messages are instantaneously relayed to you. You can also share text information or files on a chat program.
- ◆ **Interactive Video:** People can see participants' real-time video images via internet in an interactive video program.
- ◆ **Interactive Audio:** People can talk to each other real-time via the Internet in an interactive audio program.
- ◆ **Address Book:** This feature allows you to store and search for email addresses in a shared address book.

A number of industry standards have been proposed through the International Telecommunications Union (ITU) or the Internet Engineering Task Force (IETF) for Internet based data-conferencing or video conferencing software. Briefly, these standards include:

- ◆ T.120: ITU-T T.120 is a series of telephony standards developed by the International Telecommunications Union (ITU), a branch of the United Nations that develops international standards. T.120 identifies a series of communication and application protocols and services that provide support for real-time, multi-point sharing of information. The T.120 standards provide an open set of protocols for establishing, servicing, and managing the simultaneous delivery of data among multiple users connected via LAN, WAN or dial-up networks. More than 100 vendors have announced their support for the T.120 standards.
- ◆ H.320: ITU-T H.320 is a series of videoconferencing standards also developed by the International Telecommunications Union (ITU). H.320 is a set of protocols for audio, video and data conferencing over ISDN and it integrates with T.120 document-conferencing specifications to let users share documents during any H.3x videoconference. H.320 defines how videoconferencing systems communicate over circuit-switched media such as ISDN, fractional T-1, or Switched-56 lines.
- ◆ RTP: Real-Time Transport Protocol (RTP) is an industry-standard software mechanism for carrying audio and video data over IP networks. RTP was developed by the Internet Engineering Task Force (IETF) as an alternative to the widely-used TCP protocol in transporting real-time streaming audio and video data over networks. TCP was designed to deliver conventional data reliably, but in “bursts” with delivery delays that are unacceptable in real-time applications such as audio and video, where data must be received in continuous “streams.” RTP works alongside TCP to transport streaming data across networks and synchronize multiple streams. An adjunct protocol, the Real-Time Transport Control Protocol (RTCP), which monitors network conditions and reception quality.

Benefits and Drawbacks

Benefits

- ◆ Groupware enables groups of people to break the bonds of time and space. Group members can work on a project together without coming together in the same room at the same time. It saves travel time and money.
- ◆ Groupware allows more people to participate in a project and offers greater flexibility in scheduling work than would normally occur in face-to-face meetings.

- ◆ Group members can write joint documents, generate ideas, discuss problems, vote on the importance of issues, and so on by working from their offices (or anywhere there is a network connection).
- ◆ Groupware enables groups to edit, move, delete, and structure information so that it is presented in a hierarchy or map that is easy to analyze and can evolve as new information is added.
- ◆ Groupware makes parallel communication possible. With groupware, participants can use computers to type comments and send them to other group members. By typing, rather than talking, all participants can contribute information, ideas, and opinions simultaneously (i.e., in parallel) so that information is collected and shared much more quickly.
- ◆ Comments in groupware can be anonymous. This encourages candid communication which enables the group to deal with issues more quickly.
- ◆ It reduces the time needed to communicate via traditional mail, phone, or e-mail.
- ◆ It improves work productivity.

Drawbacks

- ◆ Clients must have TCP/IP Internet access.
- ◆ Most conferencing groupware clients must have the same groupware application so they can communicate and collaborate together.
- ◆ Response time for web-based groupware can be slow. Web protocols running over the Internet do not, in general, provide as fast response times as single-workstation or LAN-based systems.

URLs where demonstrated

- ◆ CoolTalk
(http://www.netscape.com/comprod/products/navigator/version_3.0/communication/cooltalk/index.html)
- ◆ CoolTalk Phone book (<http://live.netscape.com/>)
- ◆ CoolTalk Waiting Room (<http://q5.com/cooltalk/>)
(<http://www.microsoft.com/ie/ie3/>)
- ◆ Microsoft NetMeeting (<http://www.microsoft.com/netmeeting/>)
- ◆ Using NetMeeting
(<http://www.microsoft.com/netmeeting/most/using.htm>)
- ◆ Microsoft User Location Service (<http://uls.microsoft.com/>)

Implementation Details

What tool(s) were used and where did we find these tool(s)?

- ◆ CoolTalk for Netscape Navigator 3.0
(<http://www.netscape.com/>)
CoolTalk is a real-time desktop audio conferencing and data collaboration tool specifically designed for the Internet.
- ◆ NetMeeting for Microsoft Internet Explorer 3.0
(<http://www.microsoft.com/netmeeting/learn/overview.htm>)
Microsoft NetMeeting, a T.120 standards based multipoint data-conferencing product, is a real-time Internet phone voice communications client that provides true multiuser application-sharing and data conferencing capabilities.

What other tools are out there which do the same thing?

- ◆ Domino for Lotus Notes (<http://domino.lotus.com>)
Domino is an integrated HTTP/Notes server which turns a standard Lotus Notes 4 server into an Internet applications server, allowing any web client to participate in Notes applications securely. With Domino, you can render Notes files to HTML on the fly.

- ◆ **Thuridion CREW**
(<http://www.thuridion.com/products/crew/default.htm>)
CREW applications enable people to work with anyone on the Internet (or within a company Intranet) whether they have a CREW account or not.

- ◆ **neT.120 Conference Server**
(<http://www.databeam.com/Products/neT.120/>)
The neT.120 Conference Server is a standards-based product for hosting multi-point document conferences on the Internet or your corporate intranet. It also makes real-time data sharing possible over the Internet and corporate intranets.

- ◆ **Cornell University's CU-SeeMe Page**
(<http://cu-seeme.cornell.edu/>)
CU-SeeMe is a free desktop videoconferencing program which allows you to see, hear, and speak with others. You can have a direct one-on-one conversation with someone running the CU-SeeMe client software or have a one-to-many video conference by directing your CU-SeeMe client software to connect with a CU-SeeMe reflector.

Functionality Comparison for Groupware					
Functions	CoolTalk	NetMeeting	Domino and Notes	CREW	neT.120
Whiteboarding	YES (Point-To-Point)	YES (MultiPoint)	NO	NO	YES (MultiPoint)
Application Sharing	NO	YES	NO	NO	YES
File Transfer	NO	YES	YES	YES	YES
Chat	Yes (Point-to-Point)	YES (MultiPoint)	NO	NO	YES (MultiPoint)
Interactive Audio	YES	YES	NO	NO	NO
Interactive Vedio	NO	NO	NO	NO	NO
Address Book	YES	YES	YES	YES	NO
Internet Answering Machine	YES	NO	NO	NO	NO
Platform	Win 3.x, Win95, MAC, UNIX	Win95	Windows NT	Windows NT	Windows NT, Sun Solaris

Implementation using Cooltalk

How does it work?

CoolTalk is an IICE (Interactive Internet Collaborative Environment) Client Application. Insoft's IICE is a component of the Insoft OpenDVE Collaborative Multimedia Framework enabling users and developers to leverage the power of interactive applications. OpenDVE is a collaborative desktop conferencing application development environment based on the Insoft Digital Video Everywhere (DVE) software architecture. It enables true interoperability between supported Windows and UNIX desktops, video boards and networks such as Ethernet, ATM, FDDI, Frame Relay, SMDS and ISDN. CoolTalk will serve as the basis for upcoming LiveMedia framework that will be based on H.323 standard.

Why did we choose this tool?

- ◆ CoolTalk for Netscape Navigator 3.0 is easy to install and use.
- ◆ CoolTalk can be run on Windows 3.x, Windows 95, NT and a variety of UNIX systems.
- ◆ CoolTalk can handle audio conferencing - talk "live" with friends and associates across the Internet with full duplex sound so that you can speak and be heard simultaneously.
- ◆ It can save expensive long-distance charges.
- ◆ It includes a speed dialer, Caller ID functionality, Internet answering machine, call screening, and mute buttons.

What restrictions are placed on the client?

Since there is not yet a formal Internet standard for Web-based collaboration, clients must have the same software such as CoolTalk for Netscape Navigator 3.0 to communicate and collaborate. Clients also must have a full duplex sound card, speaker, and microphone to talk and hear at the same time.

What was the level of effort to implement? Summarize the implementation steps.

It takes less than half an hour to install CoolTalk on one machine and about one day to learn about how to use it.

1. Download Netscape Navigator 3.0 Standard version or just CoolTalk

You can download CoolTalk either as component of Netscape Navigator or by itself. To download it with Netscape, go to http://home.netscape.com/comprod/mirror/client_download.html select product — Netscape Navigator 3.0 Standard plus components or Netscape Navigator 3.0 Gold Standard. Select your operating system and the language you want to use. To download only CoolTalk, go to URL http://home.netscape.com/comprod/products/navigator/cooltalk/download_cooltalk.html

2. Install Netscape Navigator 3.0 and CoolTalk

Installation was simple, fast and straightforward. When the installation instructions ask “Do you want to install CoolTalk?” answer “Yes” and CoolTalk for Netscape Navigator 3.0 will be ready to work.

What did we learn about the concept / capability through implementation?

- ◆ You need a full duplex sound card and a good speaker or the sound will be choppy and you will not be able to speak and hear at the same time.
- ◆ The white board feature was awkward since no one person is in charge of it as in a face-to-face meeting. It was hard to write with a mouse and there is little room on the whiteboard to fit things.
- ◆ CoolTalk for Netscape Navigator 3.0 is ready to run on various platforms. Once you install Netscape Navigator 3.0 Standard version, you can collaborate with users who are using different platforms.

List benefits and drawbacks for the specific tool.

Benefits:

- ◆ It's easy to install.
- ◆ CoolTalk is ready for multi-platform use.

- ◆ You can call a meeting right on the Internet.
- ◆ People who work together can share ideas with each other at the same time and everyone on the meeting will see it almost simultaneously.
- ◆ A Web-based phonebook makes it easy to locate other CoolTalk users.
- ◆ CoolTalk's answering machine records messages and caller information while you're away.
- ◆ The WatchDog is a small application that runs in the background. It will register you with the 411 server and will answer incoming calls for you, automatically starting CoolTalk for you. This way you don't have to run CoolTalk all the time, but will still be available for calls.
- ◆ The 411 server provides a convenient way to locate other CoolTalk users, but is not actually required for conferencing. All conference connections are point to point.
- ◆ Apple offers a complete family of videoconferencing products that interoperate with Netscape's CoolTalk.

Drawbacks:

- ◆ CoolTalk does not support interactive video, application sharing, or file transfer.
- ◆ No one person is in charge of the whiteboard as in a face-to-face meeting.
- ◆ There is little room in the whiteboard for people to fit their comments.
- ◆ The user directory is not updated after people leave the directory.
- ◆ In the whiteboard, you can load in graphic and image files such as GIF, BMP, JPEG and JIFF etc.
- ◆ CoolTalk is one to one communication. You can only collaborate with one other person at a time.

References for more information

- ◆ Introducing Netscape Navigator 3.0 (http://www.netscape.com/comprod/products/navigator/version_3.0/)
- ◆ CoolTalk (http://www.netscape.com/comprod/products/navigator/version_3.0/communication/cooltalk/index.html)
- ◆ CoolTalk Phonebook (<http://live.netscape.com/>)
- ◆ CoolTalk Waiting Room (<http://q5.com/cooltalk/>)
- ◆ Frequently Asked Questions about CoolTalk (<http://www.insoft.com/TechSupport/CTfaq.html>)

Implementation using NetMeeting

How does it work?

NetMeeting is based on the ActiveX Conferencing platform and conforms to the T.120 protocol, the International Telecommunications Union standard for data conferencing used by telephone companies, PTTs, bridge manufacturers, video conferencing vendors, software vendors, and service providers worldwide. NetMeeting is compatible with any other conferencing program that is based on this specification, such as ShareVision from Creative Labs, ProShare Conferencing Video System from Intel Corporation, and LiveShare Plus from PictureTel Corporation.

Why did we choose this tool?

- ◆ Microsoft NetMeeting enables two or more people to share applications, transfer files, view and illustrate a shared whiteboard, and chat all over standard connections — T.120 in Internet.
- ◆ A number of companies including Creative Labs Inc., Intel Corp., networkMCI conferencing and PictureTel Corp. have announced that they have developed or are developing conferencing products and services that are interoperable with NetMeeting.
- ◆ It is easy to use and the installation is simple.

What restrictions are placed on the client?

All participating clients must have the same software (Microsoft NetMeeting or compatible software) to communicate and collaborate. Clients also must have high quality duplex sound cards, speakers, and microphones in order to speak and hear at the same time.

What was the level of effort to implement? Summarize the implementation steps.

It takes about half a day to download and install Microsoft NetMeeting on one machine and it takes about 3 days to become familiar with it.

1. Download Microsoft Internet Explorer 3.0 or just Microsoft NetMeeting
Go to <http://www.microsoft.com/ie/download/> select — IE 3.0 for Windows 95 and Windows NT 4.0. Click on NEXT and then select the language you want to use it with, for example US English - IE 3.0 for Windows 95 & NT 4.0. Click on NEXT, you will see a list of download areas from where you can download Microsoft Internet Explorer 3.0. Or you can just download Microsoft NetMeeting from <http://www.microsoft.com/netmeeting/download/>. You can select NetMeeting 1.0 (requires IE 3.0) or NetMeeting 1.0 (standalone). The difference between NetMeeting 1.0 (requires IE 3.0) and NetMeeting 1.0 (standalone) is NetMeeting 1.0 (requires IE 3.0) needs Internet Explorer 3.0 and it is smaller in size than NetMeeting 1.0 (standalone).
2. Install NetMeeting
Installing NetMeeting is simple and straight forward. You just click on the Microsoft Internet Explorer executable file and it will do the installation process for you.

What did we learn about the concept / capability through implementation?

- ◆ Application sharing runs very slowly unless you have a fast Internet connection or a 28800 modem.
- ◆ You need a full duplex sound card and good quality microphone and speakers to hear and speak at same time.

How does it contrast to other methods for doing the same thing?

NetMeeting is a standard based software which is interoperable with other T.120 conforming products. NetMeeting 1.0 supports multipoint application sharing, file transfer, whiteboard and chat tools, but it does not support Internet answering machine.

List benefits and drawbacks for the specific tool.

Benefits:

- ◆ NetMeeting supports multipoint communications in chat, whiteboard, and application sharing. Multipoint communications allow the user to hold meetings with three or more people where everyone receives the transferred files, can draw on the whiteboard, and see and control the shared applications.
- ◆ NetMeeting supports application sharing which allows you to share a Windows application with other people in an online conference whether or not the other people have the same application.
- ◆ NetMeeting is compatible with PictureTel's LiveShare Plus.
- ◆ The shared application owner can either retain complete control of the shared application or allow others access for take-a-turn editing.
- ◆ Application sharing which allows you to use applications running on the other computer over the Internet or any TCP/IP connection.
- ◆ It is easy to install and use.

Drawbacks:

- ◆ Currently, Microsoft NetMeeting runs only on the Windows 95 platform. Versions are planned for Windows NT, Windows 3.1 and Mac platform in the future.
- ◆ While you are actively collaborating with other people through the whiteboard or engaged in application sharing, the response speed will be very slow.

- ◆ You need to use the Microsoft User Location Service (ULS) server to locate the people you want to collaborate with.
- ◆ If you are on the Internet, but not currently using NetMeeting, NetMeeting can not be invoked automatically.

References for more information

- ◆ Learn about Internet Explorer (<http://www.microsoft.com/ie/ie3/>)
- ◆ Microsoft NetMeeting (<http://www.microsoft.com/netmeeting/>)
- ◆ Microsoft NetMeeting Home Page (<http://www.microsoft.com/iesupport/netmeeting/>)
- ◆ Learn About NetMeeting (<http://www.microsoft.com/netmeeting/learn/overview.htm>)
- ◆ Using NetMeeting (<http://www.microsoft.com/netmeeting/most/>)
- ◆ Call Someone Using NetMeeting (<http://www.microsoft.com/netmeeting/call/>)
- ◆ Microsoft User Location Service (<http://uls.microsoft.com/>)
- ◆ IE 3.0 Comparison Guide (<http://www.microsoft.com/ie/ie3/compare.htm#communicating>)

References for more information

Standards

- ◆ International Telecommunications Union (ITU) (<http://www.itu.ch>)
- ◆ International Multimedia Teleconferencing Consortium (IMTC) (<http://www.csn.net/imtc/>)
- ◆ Recommendation H.320 - Narrow-band visual telephone system and terminal equipment (http://www.itu.ch/itudoc/itu-t/rec/h/h320_23397.html)

- ◆ Overview of the T.120 Protocols for Audiographic Conferencing
(<http://www.csn.net/imtc/t120.html>)
- ◆ RTP: About RTP and the Audio-Vedio Transport Working Group
(<http://www.cs.columbia.edu/~hgs/rtp/>)

Groupware Information

- ◆ Collaborative Strategies (<http://www.collaborate.com/>)
- ◆ Web Conferencing Software
(<http://webcompare.iworld.com/wc.html>)
- ◆ Lotus Notes Internet Cookbook
(<http://NS.notes.net/cookbook/cbook.htm>)
- ◆ Novell's GroupWise (<http://www.novell.com/groupwise/>)
- ◆ CU-SeeMe User's Guide (<http://www.indstate.edu/msattler/sci-tech/comp/CU-SeeMe/users-guide/index.html>)
- ◆ Desktop Vedio Conferencing Resources
(<http://www-cic2.lanl.gov/documentation/videocon.html>)
- ◆ Apple QuickTime Conferencing
(<http://qtc.quicktime.apple.com/>)

Web-based Calendar

What is it?

World Wide Web scheduling software supports universally accessible Web-based calendars. When an Internet connection to your Web server is available, up-to-date schedules will be at your fingertips no matter where you are. You can update and change scheduling information on the Web as well as exchange and share data with others. Interactive web-based calendars can be used for personal and group scheduling. Some packages also support notes editing and broader information sharing.

How does it work?

Scheduling software for Web-based calendars requires a server. The server stores all the schedules, notes, and events from group members into a database. Security protection is needed to maintain access permission to the database for various users.

When the server is up, the client software installed on various platforms can communicate with the server through the Web. After username and password are verified, a user can log in to query, schedule, and create events. The private contents of an event are only viewable by the event creator, but other users can share public information and do scheduling with the other group members.

Web-based calendars work on most HTTP servers accessible from any computer platform capable of running standard Web browsers including NetScape Navigator, Microsoft Internet Explorer, and others.

Benefits and Drawbacks

Benefits

- ◆ Integrated time management.
- ◆ Personal and group scheduling.
- ◆ Scheduling via the Internet.

- ◆ Easier scheduling and time saving.
- ◆ Information views according to various categories.

Drawbacks

- ◆ Data inconsistency may occur when clients process the same time slots concurrently.
- ◆ When data changes after a query, the server cannot automatically notify clients who are viewing these data.

URLs where demonstrated

- ◆ WebCal Intranet Edition Demo
(<http://www.webcal.com/cgi-bin/demo2.0/WebCal2>)
- ◆ NetCal Demo (<http://www.itribe.net/netcal/apps/calendar>)
- ◆ OnTime Web Demo (<http://mars.ontime.com>)
- ◆ Synchronize Demo (<http://www.crosswind.com/test.htm>)

Implementation Details

What tool(s) were used and where did we find these tool(s)?

Web CAL (<http://www.webcal.com>)

What other tools are out there which do the same thing?

- ◆ NetCal (<http://www.itribe.net/netcal>)
- ◆ OnTime Web (<http://mars.ontime.com>)
- ◆ GOLDMEDAL WorkGroup
(<http://www.goldmedal.com/gm/em.html#WG>)
- ◆ GroupWise (<http://www.novell.com/groupwise/prods/gwise>)

Implementation using WebCal

Since there is currently no fully-featured trial version of WebCal server, we evaluated this package from the user point of view using the demo version of the server.

How does it work?

WebCal(tm) is an individual and groupware productivity tool for the World Wide Web. It provides the functionalities of calendars and scheduling for individuals and groups.

A single WebCal server can accommodate thousands of users. It supports universal access using standard web browsers. The server includes security features which support the administration of access privileges for all functions. Users can manage their own personal calendars, "to do" lists, and "to call" lists. They can also schedule a meeting with other group members.

While scheduling a group meeting, the Webcal search engine can check which group members have conflicts. Webcal also provides multiple calendar views, by year, day, week, month, to do, to call, and memo.

Why did we choose this tool?

- ◆ WebCal(tm) is available for any standard Unix HTTP server as well as Windows NT, Windows 95, and Macintosh servers.
- ◆ WebCal is viewable and editable from any computer platform capable of running standard Web browsers (such as NetScape Navigator, Microsoft Internet Explorer, and others) while maintaining data in a central location.

What restrictions are placed on the client?

The clients need standard Web browsers such as NetScape Navigator or Microsoft Internet Explorer.

What was the level of effort to implement? Summarize the implementation steps.

From the user point of view, it is easy to implement Webcal through its online help feature.

What did we learn about the concept / capability through implementation?

Webcal is useful for personal and group scheduling. Its most important benefit is integrated time management. However, the user must use the search engine to detect conflicts since the package does not automatically identify them when a meeting time is proposed. It does not show the free time slots of the people involved or notify users that a conflict needs to be resolved.

How does it contrast to other methods for doing the same thing?

In general, all Web-based calendar software packages have the following features:

- ◆ Work with leading Web Servers.
- ◆ Work with a variety of Web Browsers.
- ◆ Personal and group scheduling.
- ◆ View both appointments and tasks.
- ◆ View meeting details.
- ◆ Search features.
- ◆ Day, week, and month views.

Webcal's single server can accommodate thousands of clients, unlike others which handle fewer than one hundred. In addition to the day, week, and month views, WebCal also has year view and view by "to do" or "to call." Both WebCal and OnTime Web offer online help. OnTime Web supports RSVPs; WebCal does not.

Synchronize can do many of the same things as WebCal. It is an Internet-based calendar instead of a Web-based calendar. Users install client side viewers to connect to the server. It has some advantages over Webcal: free time slots of all people are viewable before scheduling, it offers better performance since it does not contact Web servers, and the calendar printouts are more detailed. The drawbacks of Synchronize are its inability to work with Web

Browsers, it supports fewer than one hundred clients, and it requires extra client side software.

List benefits and drawbacks for the specific tool.

Benefits:

- ◆ WebCal's single server accommodates thousands of users.
- ◆ It provides for universal access using standard web browsers.
- ◆ Easy to use and maintain.
- ◆ Can create and track any number of calendars and lists.
- ◆ Offers multiple calendar views, by year, day, week, month, to do, to call, appointment and memo.
- ◆ Offers user customizable graphics.
- ◆ Includes e-mail reminders.

Drawbacks:

- ◆ Since a single server accommodates thousands of users, it is more vulnerable to security intrusions.
- ◆ There is no RSVP function.

References for more information

- ◆ How to Use WebCal Intranet Edition
(<http://www.webcal.com/ie.help/index.html>)

Chapter 5. Education and Training Services on the Web

Overview

The convergence of telecommunications, telephony, and computing has made possible an evolution from the traditional educational model to a new learner centered model. Dr. William Graziadei of SUNY Plattsburgh sees the next decade as a time when “telecommunication technology will exert increasing influence over the ways in which learners and those who assist them spend their time.” He says the convergence connects the participants “in ways not previously possible and thus provides access to instruction and training information WHEN, WHERE, HOW, and AS MUCH as the learner wants.”

John Gehl, editor of the *Educom Review*¹, in a November/December 1996 article “The Curriculum has Run its Course,” calls for less focus on the where and when of education and more about the what and the why. He too, sees the convergence of technologies as the opportunity to reduce the bureaucracy of education and to focus on the goals of education.

Often times students drive this innovation through the establishment of e-mail groups and “class homepages” where information and ideas can be shared. Instructors have also found using the WWW for the submission of assignments and the dissemination of information to be extremely valuable. The State of New York has begun investigating the possibilities of using the Web as a mechanism to provide training videos. Under such a plan employees would be able to access training films whenever their schedules allowed.

How do we get there from here? As educators struggle with this question, institutions are taking advantage of a wide range of Web technologies to deliver research, reference, teaching, learning, and training services. These Web-based services can range from simple information dissemination such as a course catalog to a full course management system all the way to an extensive program of all the courses leading to a degree.

Education and training are provided by colleges, universities, and schools and (increasingly) by industry, government and nontraditional sources. Grassroots efforts are taking place across the nation to bring

schools into the Internet era (such as NetDay '96). The Internet II Project, the next generation of university networks for the national research community has begun “in response to the growing privatization of the network and the frequent congestion of its commercial replacement.” Over the next three to five years as many as a hundred universities, a number of federal agencies, and many of the leading technology vendors will work on the “Internet II Architecture.” While there are already thousands of educational opportunities on the Web, these developments signal enormous growth ahead.

Our research for this project highlighted both benefits and limitations in the use of the Web in the educational process:

- ◆ Lower cost to deliver courses and training materials to students and staff. Courses that would otherwise be difficult to offer at some campuses because of limited enrollment or lack of faculty in a specialized area are now possible. Business can reduce the time and cost associated with travel time for training.
- ◆ Greater opportunity for collaboration and sharing. The Web increases opportunities for collaborative work and sharing of information, ideas, and courses among campuses.
- ◆ Greater access to courses that can be taken any time, any place. “Anywhere” courses can be delivered to a learner at a campus, at the office or at home, and the time may be “any time.” Distance learning can be supported in both synchronous (same time) and asynchronous (different times) modes. Equity of access to certain courses can be improved as courses that would not be possible at some campuses because of limited enrollment or lack of faculty are now possible.
- ◆ Greater access to research and reference services. The Web offers access to indexes of current journals, full text of articles, electronic references, and extensive full text search facilities with millions of documents available for the asking.

Current Uses of the WWW for Education and Training: Practical Results

The use of the WWW in education and training is in its infancy but growing rapidly. Providing an environment where learners can access necessary and appropriate materials, proceed at their own pace, receive feedback, and monitor their progress seem to be core goals among those involved in Web-Based Training (WBT) and Web-Based Education (WBE). The Web itself, of course, is a good source of discussion on the role of the Web in education and training. A list of relevant articles and sources is provided in the References section at the end of this chapter.

This chapter presents examples of implementations of the Web as a technology to support a learner centered model of education and training. The benefits and limitations of the increasing trend toward Web-based instructional services in the academic, public, and private sectors are presented. Additional references to support efforts in Web-based education and training are also provided.

Web-Based Education

“For me, this is the answer to my prayers,” said one student, Patricia Smith of Neversink in Sullivan County, New York. “I always get front row parking, I’m never late for class, I never have a bad hair day, I can pass notes to my classmates and not get into trouble, and I can get up in the middle of class to grab a cup of coffee or read a book to my two-year old grandson. The class is waiting for me when I get back and I haven’t missed a thing.” (http://www.sysadm.suny.edu/university_relations/newsrel/961119-4.htm)

The SUNY Learning Network (<http://www.sln.suny.edu/sln>), where Patricia Smith is a student, allows students to take individual courses from multiple campuses for professional or personal enrichment or to earn a degree right in their own homes, at their own pace and time schedule. The SUNY Learning Network is one of 40 projects funded by the Alfred P. Sloan Foundation (<http://www.sloan.org/top.html>) to assist colleges and universities in their efforts to implement Web-based instruction. The SUNY Learning Network provides this opportunity over what is known as an Asynchronous Learning Network (ALN), which uses computers and the Internet as a vehicle for an on-going dialogue among students and faculty.

ALN, according to the SUNY Learning Network, eliminates the constraints of time and location that higher education usually places on students. ALNs also emphasize innovative instruction and learning. The activities of a traditional class are the same — students read course materials, write papers, do research, and communicate with their instructor and fellow students, but students, and the faculty, use technology to accomplish these tasks. The course design facilitates these activities through a computer network. The learning is both interactive with faculty and collaborative with other students. Access to other resources on the Web is also available to support the instructional process.

Many universities are implementing ALNs. SUNY's implementation however, is receiving particular attention from the Sloan Foundation. "We are delighted with the success of the SUNY Learning Network. It is the only project we know of that provides courses in this way on a system or multi-campus basis," said Dr. A. Frank Mayadas, program officer for the Sloan Foundation. "This asynchronous project is extremely valuable because it establishes remote access to course work at the student's convenience - (on demand) so to speak - and its prime focus is linking people to other people, providing a framework for their interaction," Dr. Mayadas said.

The SUNY Learning Network is currently an association of eight colleges in the Mid-Hudson Region (SUNY New Paltz; SUNY Empire State College; and Ulster, Rockland, Orange, Sullivan, and Columbia-Greene Community Colleges) who have joined together to offer on-line college courses to two bachelors degrees:

- (1) a B.S. in Business, Management and Economics from SUNY Empire State College; and
- (2) a proposed B.A. in Liberal Studies from SUNY New Paltz.

In its first year, the SUNY Learning Network offered four courses in each semester. Fourteen courses were offered in the fall of 1996 and 63 students were enrolled in one or more courses under the program. Due to the success of the program the number of courses available will be expanded to 20 in the spring of 1997. To further the multi-campus model the SUNY Learning Network plans call for adding at least 10 additional campuses during each of the next three years eventually expanding the course offerings into the hundreds and serving 1,000 students by 1997-98. Expansion ultimately will include campuses from all sectors of the State University: its university centers, four year colleges, colleges of technology, specialized colleges and community colleges.

"Because of our success this past year we are more than tripling the number of online courses to be offered this fall," said Interim Chan-

cellor John W. Ryan. “This is an extremely convenient way to take high quality courses and even earn an accredited bachelors degree,” Dr. Ryan said, noting that the SUNY Learning Network helps overcome the increasing challenges facing more and more adult and non-traditional college students.

One student, with limited computer experience, said, “I could see little use for computers in my life. Taking the on-line course changed all that...The knowledge and interest I gained about computers from the Learning Network experience was an unexpected advantage.”

Faculty have found their students to be highly motivated, and have been extremely impressed with student performance. “The level of class participation and discussion far exceeded, in quantity and quality, anything I have ever experienced in the traditional classroom setting,” said David Jaffee, a New Paltz professor who teaches Social and Economic Development via the SUNY Learning Network. Jaffee feels that “it is vital that one approach the distance learning course with some explicit pedagogical principles and strategies, and exploit the technology in order to close the gap between the isolated independent student and other human participants — namely, instructors and students — who can enhance the learning process.” The principles and practices that Jaffee incorporated in his Social and Economic Development course include interactivity, mediation, active learning, and collaborative learning.

Web-based Training

The potential for using the Web as a delivery mechanism for professional training is being explored by many organizations as a way to ensure that employees receive the training necessary to do their jobs while dealing with the “do more with less” reality of the modern workplace. With the “any time, any place” communication styles resulting from use of the Web, the evolution of the training environment from current modes of Lecture-Based Training (LBT) and Computer-Based Training (CBT) to Web-Based Training (WBT) seems natural.

Tom Kilby of the Web Based Training Information Center (<http://www.clark.net/pub/nractive/alltrain.html>) offers the following definition of Web-based training:

Web-based training (WBT) is an innovative approach to distance learning in which computer-based training (CBT) is transformed by the technologies and methodologies of the World Wide Web, the Internet, and intranets. Web-based training presents live content, as fresh as the moment and modified at will, in a structure allowing self-directed, self-paced instruction in any topic. WBT is media-rich training fully capable of evaluation, adaptation, and remediation, all independent of computer platform.

New models of training are being developed to take advantage of the Web as a delivery mechanism. These models are emerging from both public and the private sectors. One model presented by Elwyn Jenkins and Helene McKenzie of Web Australia (<http://www.webaustralia.com.au/magazine/articles/edu1b.htm>) enables web-based training to be “individualized, customized, modular, accessible, self-paced, interactive and competency based.” They state that for training to be effective it must “be available and easily implemented in the work place, accessible at the right time for the right people, be relevant to the needs of its clients (customized) and the final users (individualized), inexpensive, easily maintained, self-paced and interactive.”

Lawrence Livermore National Laboratory - Prototype Web-Based Training

(<http://www.orau.gov/seed/sers/sersllnl.htm>)

At the Lawrence Livermore National Laboratory (LLNL) the use of the Web as a delivery mechanism for “on-the-job” training is seen as a natural next step beyond Computer-Based Training (CBT). The key advantage of CBT over traditional lecture-based training (LBT) is that it allows the training to take place on an individualized basis. Training can take place when the person requires it, or when they have opportunity in their work schedule, rather than when the instructor is available and there are enough students to hold a class. A significant disadvantage of CBT remains the need for specialized equipment in a specific location. The addition of the Web to the model of CBT removes the need to be in a particular location and enables on-the-job training to take place “any time, any where.”

LLNL is developing a prototype “on-the-job” training environment which will support the constant need for training in their highly specialized and technological environment. (<http://lucky.llnl.gov/wbt>) In a position paper on this prototype approach entitled, “The World-Wide-Web as a Medium for Presenting LLNL Training Courses,” (<http://lucky.llnl.gov/wbt/wbt>) Darrel Lager and Sue Koopman present a number of advantages of web-based training (WBT) over conventional LBT.

- ◆ Students can view the course materials at any time and rate since the Web is always available.
- ◆ Students can view the materials in familiar surroundings — their normal workplace or home.
- ◆ There is no need to schedule classes, instructors, or classrooms.
- ◆ The instructor spends less time lecturing. For many on-the-job training courses the instructor is a fellow worker or a supervisor so less lecture time reduces time the instructor/supervisor is taken away from normal duties.

In addition, they identify a number of advantages of WBT over CBT including the following:

- ◆ A large (and growing) number of people are already familiar and comfortable with the Web browsers so they are already familiar with the user interface.
- ◆ Course materials become reference materials with updates immediately available to everyone.
- ◆ With the Web it is easy for the course author to include links to other materials.
- ◆ The language of the Web, html, is very easy to learn so course authors need little training before producing course material.

The prototype implementation at LLNL includes two courses selected

because they exemplify the characteristics identified by Lager and Koopman as most natural to presentation on the Web. The first, Hazards Control Personnel, contains the type of orientation information that does not require interaction between the trainer and the student. This includes photo images of personnel and facilities, maps, organization charts, and descriptions of facilities.

The second, a course on Safing a Laser Amplifier, represents an effort to cut production costs. Through the use of html documents, animation, and photographic images, individuals can become familiar with equipment without necessarily having to disturb an on-going experiment. A floor plan of the facilities, included in the prototype, provides icons in particular rooms which link to the appropriate on-the-job training course for that room.

The limitations of existing browsers and protocols in the administration of tests presents a difficult challenge for WBT efforts. The approach taken in the prototype at LLNL is to provide a web-based true/false, multiple choice test for evaluating how much of the information the student has absorbed. This approach works in an environment where the "test" is as much a self-assessment tool as it is a mechanism for documenting retention. In a different environment measures would need to be taken to authenticate the identity of the test taker.

This "proof-of-concept" prototype is being used to inform decision makers about the advantages of the WBT approach and to identify the teams needed for implementation.

U.S. Department of Energy, Office of Training and Human Resource Development

(<http://www.inel.gov/hr2/att/att-head.htm>)

In 1995, the U.S. Department of Energy (DOE) undertook an extensive nationwide review of organizations in the process of implementing a wide variety of advanced training technologies (ATT). The results are presented in a report entitled "A Study of Advanced Training Technology: Emerging Answers to Tough Questions." The report presents a comprehensive set of results which includes:

1. A taxonomy developed by experts at AT&T to differentiate different kinds of multimedia and courseware applications based on complexity.
2. Twenty lessons learned from the comparative case studies conducted presented in six categories:
 - ◆ Training technology integration
 - ◆ Contracting, staff, logistics and resource management
 - ◆ Accreditation

- ◆ Focus and audience
 - ◆ Cognitive engineering
 - ◆ Systems thinking
3. A set of tools for decision making and planning.
 4. A model for assessing organizational readiness for ATT.

The report concludes with a set of 12 specific recommendations which primarily reflect the need for thorough strategic planning including needs analysis, cost/benefit analysis, skills development, prototyping, and assessment tools.

Can the Web support Multimedia Training?

In a February 1996 Inter@ctive Week article “The Internet As Training Ground,” Joe McGarvey presents cost figures for CBT. In 1995, corporations spent more than \$730 million on multimedia-based training for employees and customers, according to Ellen H. Julian, an analyst with International Data Corp., a Framingham, Mass. research firm. In 1996, the number was expected to exceed \$850 million. (<http://www.zdnet.com/intweek/print/960212/digitdev/doc2.html>)

McGarvey suggests that the Web may be an acceptable alternative to the costly current methodologies for CBT. The advantage of WBT according to Julian “is that changes to curricula, whether large or small, need only be made in one place, a central server.” McGarvey points out however, that although video and audio broadcasting technologies are available they “cannot yet compete with a CD-ROM, which can deliver lush stereo sound and television-quality video.”

To accommodate this limitation of the Web and to address the high cost of distribution a hybrid approach is emerging which combines the strengths of both mediums. The Web is used to store time sensitive information and the CD-ROM is used to provide access to the sparkle of multimedia training. The courseware on the CD has built-in Internet access and calls upon the centralized server for necessary information. Organizations can update time-sensitive information once on the central server. According to Kathy Godwin, president of Highlight Interactive, an Austin, Texas multimedia developer, “it’s a matter of using the right tool for the right job.” Industry analysts expect this to be a popular alternative to full web-based training until bandwidth constraints have been resolved.

Benefits and Drawbacks of Web-based Education and Training

Interactive, collaborative, on-demand, current, and accessible. These are some of the concepts that are being used to guide the development of Web-based education and training initiatives. Throughout the literature and the case examples, these concepts drive the planning and development of Web-based tools for both education and training. The Web itself provides access to a growing collection of resources on the planning, implementation, and evaluation of Web-based education and training. Looking to the Web for strategies in these areas can inform decisions regarding the integration of the Web in education and training programs. Looking to an organization's leaders to provide context, goals, and support for the initiative is instrumental in achieving success.

The SUNY Learning Network and similar initiatives are key cases which provide insights into overcoming the limitations and enhancing the benefits of Web-based instruction. The following benefits and limitations of Web-based education and training are derived from the literature and the initiatives discussed above.

Benefits

- ◆ Students can view materials from a common user interface - the Web.
- ◆ Students can view the course materials any time, any place.
- ◆ Students can view materials from the regular desktop workstation.
- ◆ Saves resources associated with physical gathering of a set of students with an instructor.
- ◆ Courses are more accessible to a wider range of students.
- ◆ Greater ability to take time to compose thoughts contributed to class discussions on newsgroups and listservs.
- ◆ Higher level of interactivity than in a traditional classroom.
- ◆ A large (and growing) number of people are already familiar and comfortable with the Web browsers so they are already familiar with the user interface.
- ◆ Course materials become reference materials with updates immediately available to everyone.
- ◆ With the Web it is easy for the course author to include links to other materials.
- ◆ The language of the Web, html, is very easy to learn so course authors need little training before producing course material.

Drawbacks

- ◆ Less human, face-to-face interaction.
- ◆ Information validity and authenticity can be difficult to determine. There is a need for a “library” function to catalog, identify, and verify information.
- ◆ Rapid commercialization on the Web is resulting in a preponderance of vendor advertising, “info-mercials” and skewed information on the Web.
- ◆ Distraction, one can become sidetracked because of the wealth of material on the net.
- ◆ “Turf”, distributed, virtual campuses extend and overlap across traditional boundaries.
- ◆ Intellectual property rights can be unclear.
- ◆ Hardware and network connections for users may be unavailable.
- ◆ The hypertext environment limits ability to control the entry point for instructional purposes.
- ◆ The Internet methods of communication may be intimidating or awkward to use for some students.
- ◆ There is a lack of incentives for instructors to learn and use technology.
- ◆ Bandwidth limitations can make some interactive applications too slow for effective learning.
- ◆ Reliable computer equipment and technical support for that equipment can be costly.
- ◆ Existing browsers and protocols have limited usefulness in the administration of tests.
- ◆ Difficulties in controlling payment, registration, and authentication of “students.”

References

Distance Education: Theory and Practice

<http://seamonkey.ed.asu.edu/~mciaac/dised.html>

Introduction to Astrophysics

<http://dept.physics.upenn.edu/~myers/astro11>

Art, Design, and Visual Thinking: An Interactive Textbook

<http://char.txa.cornell.edu/zbs/webdocs/home.html>

Interactive Real Analysis: An Interactive Textbook

<http://www.shu.edu/~wachsmut/real/about>

NASA K-12 Internet Initiative

Courseware and Training Materials

<http://quest.arc.nasa.gov>

SUNY Learning Network
<http://sok.sysadm.suny.edu/sln>

Writer Workshops in Essay Writing, Punctuation, Grammar and Style,
<http://www.esc.edu/htmlpages/writer/workshop.htm>

WEST, Teaching and Training On-Line
<http://137.142.42.95/west/demo.html>

Virtual Courses on the Web
<http://lenti.med.umn.edu/~mwd/courses.html>

Web-Based Course Management Systems
<http://137.142.42.95/west/WebInClass/CMS&ETI.html>

Articles

Distance Education on the WWW S.Lintz et S.Tognotti, TECFA,
<http://tecfa.unige.ch/~lintz/staf14/staf14+ST/projet.html>

Changing Nature of Instructional Delivery and Teaching-Learning Environment
<http://137.142.42.95/TL/Change.html>

Evaluating the Value and Effectiveness of Internet-Based Learning
<http://mediaserver.slis.uwo.ca/research/papers/inet96/edu/paper/>

A Comparative Analysis of Web-Based Testing and Evaluation Systems
<http://renoir.csc.ncsu.edu/MRA/Reports/WebBasedTesting.htm>

Teaching and Learning with Internet Tools: A Position Paper
<http://tecfa.unige.ch/edu-ws94/schneider/schneide.fm.html#hd7>

Designing and Implementing Instruction on the World Wide Web:
A Case Study
<http://lrs.stcloud.msus.edu/ispi/proceeding.html>

A selection of Judi Harris' columns from The Computing Teacher/Learning and Leading with Technology.
<http://www.ed.uiuc.edu/Mining/Overview.html>

The World Wide Web in Education: A Closer Look
<http://k12.cnidr.org:90/web.intro.html>

Organizing educational network interactions: Steps towards a theory of network-based learning environments

<http://www.ed.uiuc.edu/Guidelines/Levin-AERA-18Ap95.html>

A Study of Advanced Training Technology:
Emerging Answers to Tough Questions
<http://www.inel.gov/hr2/att/att-home.html>

A Model for Web-Based Learning Systems for On-the-job Training
Part I <http://www.webaustralia.com.au/magazine/archives/edu1a.htm>
Part II <http://www.webaustralia.com.au/magazine/articles/edu1b.htm>

The Internet As Training Ground
<http://www.zdnet.com/intweek/print/960212.digitdev/doc2.html>

Resource Directories

The World Lecture Hall
<http://www.utexas.edu/world/lecture/index.html>

EduWeb University of Southern Australia
<http://www.netspot.unisa.edu.au/eduweb>

EdWeb World Wide Web in Education Andy Carvin, CNIDR,
<http://edweb.cnidr.org:90/web.intro.html>

On-Line Educational Resources
<http://quest.arc.nasa.gov/OER>

The Global Knowledge Exchange
<http://www.GKE.com>

GlobeWide Network Academy
<http://www.gnacademy.org:8001/uu-gna/>

Education World
<http://www.education-world.com>

The Internet University
<http://www.caso.com>

Classroom Connect
<http://www.classroom.net>

Web Based Instruction (WBI)
<http://interact.uoregon.edu/CATE/FA/Webinstruction>

Web-Based Training Related Links
<http://www.clark.net/pub/nractive/f4.htm>

¹ Educom is a nonprofit consortium of colleges and universities which addresses critical issues about the role of information technology in higher education

Chapter 6. Appendices

Appendix A. Project Timeline

Appendix B. Project Participants

Appendix C. Related Products

Appendix D. Evaluation Template

Appendix A. Project Timeline

February 1996	Proposal Selection Call for Corporate Participation
March 1996	Universal Interface Project Strategy Planning Session
April 1996	Security on the Internet Identification of Types of Services to be Investigated
August 1996	Selection of the America's Job Bank for Conducting Business case study First prototype of Web-based Cost and Performance Worksheet
September 1996	Presentation at Government Technology Conference
November 1996	Deloitte and Touche demonstration of Web to Legacy Prototype to SUNY and CTG Public Demonstration of Results
December 1996	Final Project Report

Appendix B. Project Participants

SUNY System Administration

Joseph W. Sasiadek, Coordinator of Systems Integration

Edward J. Urschel, Director of Systems Development For Finance and Management

Bruce D. Briggs, Manager of Technical Services

Thomas F. Cusack, Project Manager

Michael J. Plowinske, Manager of Systems Programming

Bluestone, Inc.

Division of Housing and Community Renewal

Audrey Dean, Associate Computer Programmer Analyst

Empire State College, Center for Learning and Technology

Larry Greenberg, Multi-Media Instructional Developer

EMI Communications Corporation

William Gaudet, Senior Account Executive

Deloitte & Touche Consulting Group / DRT Systems

Ronald R. Schrimp Sr., Project Manager

Cecil Elmore, Public Relations, Project Advisor

Jeff Older, Technical Architect

Stefan Estus, Internet Developer

Ramesh Karan, Internet Developer

Terri LeMarche, Project Liaison

Bettina Conroy, Project Support

Microsoft Corporation

Connie Mitchell Dean, Government Account Representative

Gary Falis, Systems Engineer

NYNEX

Neil Corkery, Data Communications Manager

NYS Forum for Information Resource Management

Mandy McCord, Information Systems Administrator

NYSERNet, Inc.

James P. Brennan, Assistant Director of Government Services

Denis J. Martin, Senior Director of Software Engineering

Office of Real Property Services
Brian Bitteker, Internet Applications Developer

Silicon Graphics
Ed Balduf, Systems Engineer
Florence Matla Huban, Account Manager
Nelson Frolund, Manufacturing Industries Engineer
Andrew Schein, Systems Engineer

SUNY Plattsburgh
William D. Graziadei, Professor, Department of Biological Sciences

University at Albany
John Rohrbaugh, Professor, Department of Public Administration and
Policy
Eliot Rich, Student, Information Science Doctoral Program
Gary R. Pelton, Director, Telecommunications Office
Donald Gallerie, Associate Director, Data Communications, Telecom-
munications Office

Center for Technology in Government
Donna Berlin, Internet Coordinator
Ann DiCaterino, Project Support Manager
Sally Goodall, Operations Team Leader
Darryl Green, Project Support Manager
Kai Larsen, Graduate Assistant
Theresa A. Pardo, Project Coordinator
Mei-Huei Tang, Graduate Assistant
Wen-Li Wang, Graduate Assistant
Derek Werthmuller, Systems Administrator

Appendix C. Related Products

“A World Wide Web Starter Kit,” Center for Technology in Government, Albany, NY 1996. Electronic version at <http://www.ctg.albany.edu/projects/inettb/startkit.html>

“Security Day Seminar,” Center for Technology in Government, Albany, NY, 1996. Electronic version at <http://www.ctg.albany.edu/projects/inettb/security.html>

Dawes, Sharon S., Theresa Pardo, Peter Bloniarz, Ann DiCaterino, Donna Berlin and David Connelly, *Developing & Delivering Government Services on the World Wide Web: Recommended Practices for New York State*. Center for Technology in Government, Albany, NY, 1996. Electronic version at <http://www.ctg.albany.edu/projects/inettb/pract2.pdf>

Pardo, Theresa A., David R. Connelly, and, Sharon S. Dawes, *Delivering on the Web: The NYS Internet Services Testbed*. Center for Technology in Government, Albany, NY, 1996. Electronic version at <http://www.ctg.albany.edu/resources/pdfrpwp/istfnlrp.pdf>

Appendix D. Evaluation Template

For Concept or Capability Investigated:

- ◆ What is it?
- ◆ How does it work?
- ◆ URL where demonstrated:
- ◆ What tool(s) were used to implement the prototype/application and where did we find these tool(s) (URL, etc.)?
- ◆ What other tools are out there which do the same thing?
- ◆ Why did we choose this tool?
- ◆ What restrictions are placed on the client (such as plug-in needed, only works with certain browsers, etc.)?
- ◆ What was the level of effort to implement (how long and how hard)? Summarize or list the implementation steps. Supply a diagram if it will further understanding of the implementation.
- ◆ What did we learn about the concept / capability through implementation?
- ◆ How might the concept / capability be employed for other applications? How does it contrast to other methods for doing the same thing?
- ◆ List the benefits and drawbacks, both for the concept and for the specific tool.
- ◆ List references (URLs, magazine articles, books, etc.) which may be useful for more information.

**Center for Technology in Government
University at Albany / SUNY**

**1535 Western Avenue
Albany, NY 12203**

Phone: 518-442-3892

Fax: 518-442-3886

ctg@atlas.cc.albany.edu

www.ctg.albany.edu